

PORTATİF ÇUVAL AĞZI DİKME MAKİNASI
PORTABLE BAG CLOSING MACHINE

KULLANMA TALİMATI PARÇA LİSTESİ
INSTRUCTION MANUEL – PARTS LIST

Model NP-7A

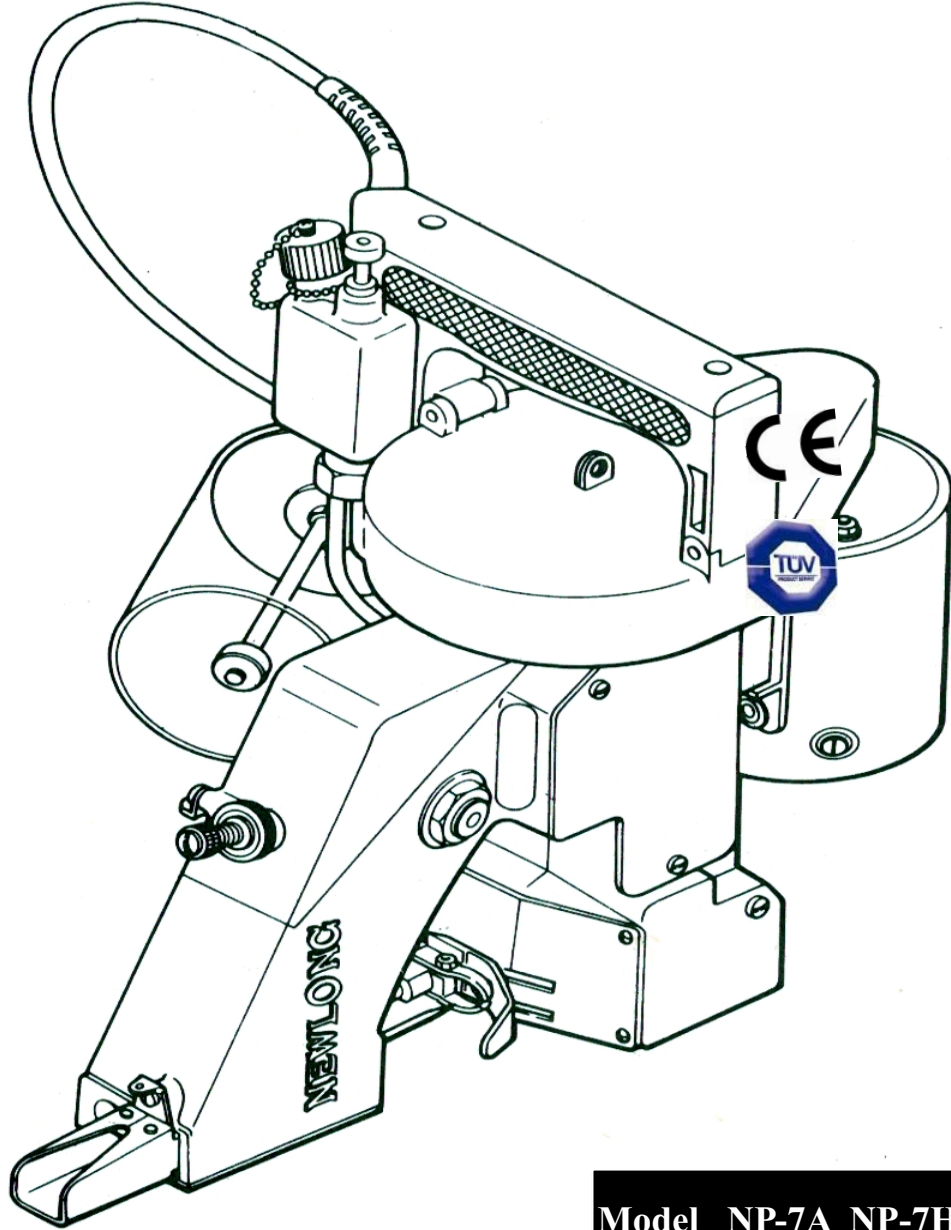

Model NP-7A NP-7H NP-7K
NP-7II NP-7W N-7III



PORTABLE BAG CLOSER MODEL NP-7A



*HIGH-SPEED NEW TYPE WITH
PLASTIC HANDLE AND LUBRICATOR*

SINGLE THREAD CHAIN STITCH

- High speed revolution.
1,475-1,725r.p.m.
- Safety plastic handle for insulation.
- Oil pump lubrication system.
Oil lines direct lubricant to main
moving elements.
- Improved looper and simple mechanism
- Steel cam (no plastic cams)
- Automatic thread cutting
- Minimum maintenance
- For kraft paper, cotton, hessian,
jute, PP/PE woven cloth and other

GEDİKLİ & ENKA

s.ayhangedikli@enkagedikli.com

www.enkagedikli.com

www.nasadegirmen.com

www.newlondikismakinalari.com

www.polyestercuvaldikisipi.com

7 / 24 Tel : 0532 437 04 35

Tel: 0212 320 36 64 Fax: 0212 320 36 92

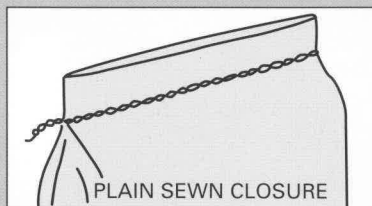
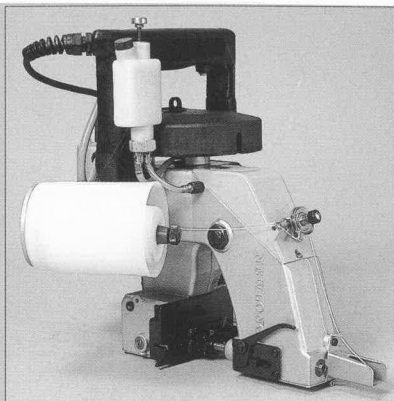

PLAIN SEWN CLOSURE



SINGLE THREAD CHAIN STITCH
with one each needle and looper.

NEWLONG MACHINE WORKS, LTD.

14-14, Matsugaya 1-Chome, Taito-Ku, TOKYO 111-0036, JAPAN

Telephon: 03-3843-6548 Facsimile: 03-3843-6574

NEWLONG

CE Type

Portable bag Closer Model NP-7A High-Speed Type with Plastic Handle & Lubricator

- Ideal for closing bags for agricultural products, animal feeds, fertilizer, flour, chemicals, etc.
- Robust construction and safety design
- Trouble-free continuous operation

SPECIFICATIONS

Revolution(r.p.m.)	1,600±125
Stitch length	8.5mm(3 per inch) fixed
Needle	DNx1 #25
Weight	6kg(13 lbs)with thread
Drive motor	65W-220V 70W-230V~240V 50/60Hz, 1Ph (please specify one when ordering.)

★ TAPE BINDING ATTACHMENT available at extra cost.

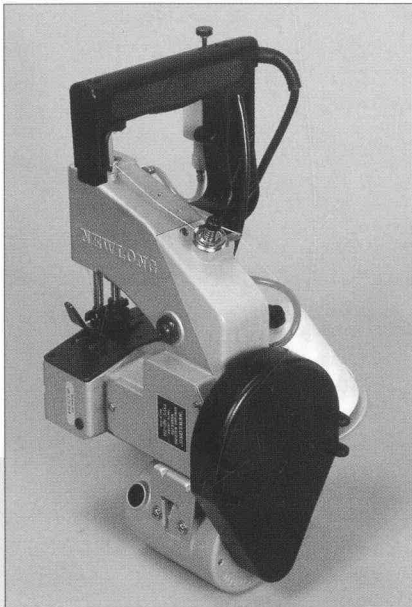

MODEL NP-7H SIDE HANDLE TYPE

Easy sewing on horizontal surfaces.
Suitable for joining two fabrics.

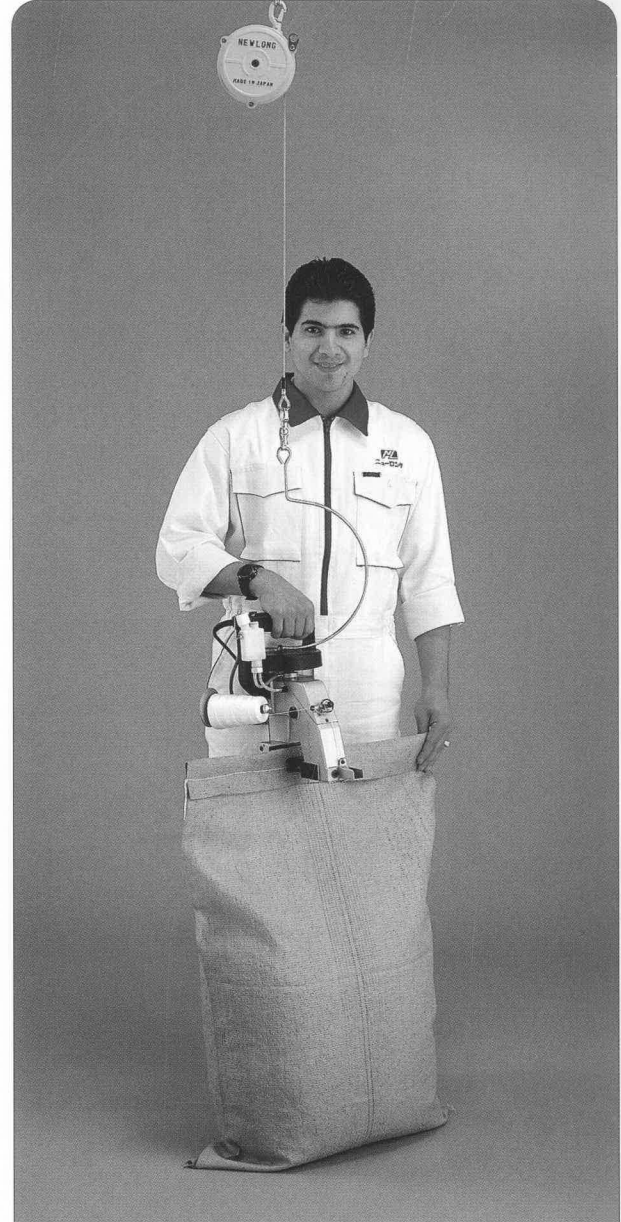

OPTIONAL USAGE

NP-7A in use being suspended on the
SPRING BALANCER with HANGER
(available at extra cost)



Machine Mills Industrial Equipments Spare Parts Trade Group
Head Office;

Perpa Ticaret Merkezi A Blok K.7-8-9 N.714 34384 Okmeydanı Şişli-İSTANBUL/TÜRKİYE
Tel: 0212 3203664 Fax: 0212 3203692 7/24 Gsm:0532 4370435
s.ayhangedikli@hotmail.com s.ayhangedikli@enkagedikli.com

www.enkagedikli.com www.nasadegirmen.com www.newlongdikismakinalari.com www.polyestercuvaldikisipi.com

Flour-Feed-Food Industrial Machine Equipments Spare Parts.

1) ÖZELLİKLERİ

Teknik Özellikleri

Hızı	: 5 - 6 çuval/saniye
Dişi tipi	: Tek ip zincir dikiş
Dikiş aralığı	: 7.2 mm.
Devir	: 1600 devir/dakika
İğne	: DN x 1 25 no.
İplik	: 20/4 polyester veya pamuk
Motor	: 60 W
Elektrik	: 220 V 50 Hz, monofaz
Net Ağırlık	: 4.5 kg.

Standard Aksesuarları

İğne DN x 1 25 no	: 5 adet
İplik 20/0 4-5	: 1 rulo
Anahtar	: 1 adet
İğne anahtarı	: 1 adet
Yağdanlık	: 1 adet

1) SPECIFICATIONS

Technical Details

Speed (sec/bag)	: 5 - 6
Seam	: Single Thread Chain Stitch
Stitch Range (mm.)	: 7.2 (fixed)
Revolution (rpm.)	: 1,600 \pm 125
Needle	: DN x 1 - 25
Thead (vinyon, synthetic or cotton)	: 20/6
Drive Motor	: 60 W
Power Supply	: 110, 220 or 240 V., A.C. 12V, 24V., D.C. (specify one.) 50-60 Hz, Single Phase
Net Weight (kg)	: 5.2 Including Thread Cone, Shoulder Belt.
Machine Dimension (mm.)	: 360 (L) x 245 (W) x 315 (H)
Packing Dimension (cft.)	: 2.5

Standard Accessories

1. Needles DN x 1 - 25	: 5 pcs.
2. Thread Vinyon 20/6	: 1 roll
3. Screw Driver	: 1 pce.
4. Needle Bar Spanner	: 1 pce.
5. Oil	: 1 can

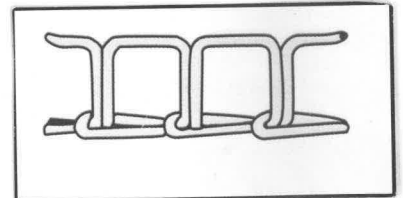
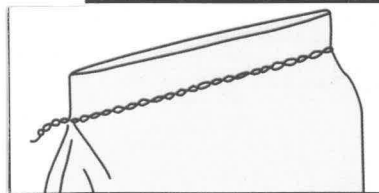

2) ÇALIŞMAYA HAZIRLAMA

1. Yağlama (Resim 1)

Makinanın ömrünün artırılması yağlama ile mümkündür. Yağ rezervuarını standard makina yağı ile doldurunuz. (45 cc.) Yağlama için rezervuarın üstündeki düğmeyi pompalayın. Her defasında 0.08 cc yağ dağıtılır. Makinayı yağsız vaziyette kullanmayın aksi halde kırılma yapabilir.

2. İğne takma (Resim 2,3,4)

İğne kolu en uzun noktasına gelene kadar motor kayışını el ile çeviriniz. İğne kolu civatasını sonuna kadar gevşetin. İğneyi girdiği kadar yerine yerleştirin. İğnenin yuvarlak kısmının Luper tarafına doğru olmasına dikkat edin. Somunu sonuna kadar iyice sıkın aksi halde çalışma sırasında gevşer ve kırılır.

3. İp takma (Şekil 5)

Makina üzerinde takılı iri ipliği ile beraberdir. İlk çalıştırmadan önce takip ettiği yolu inceleyiniz. Şekil 5'deki gibi 1'den 6'ya kadar gösterilen sıraları takip ediniz. İpliği dışa doğru bırakın.

- | | |
|--------------------|----------------|
| 1. İp deliği | 4. İğne çubuğu |
| 2. İp germe deliği | 5. İp deliği |
| 3. Frenleme deliği | 6. İğne |

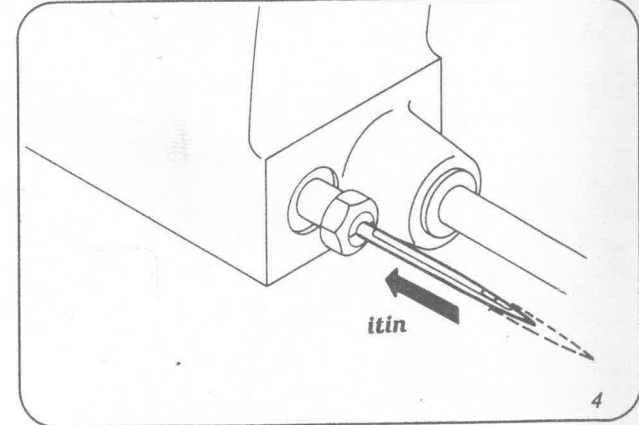
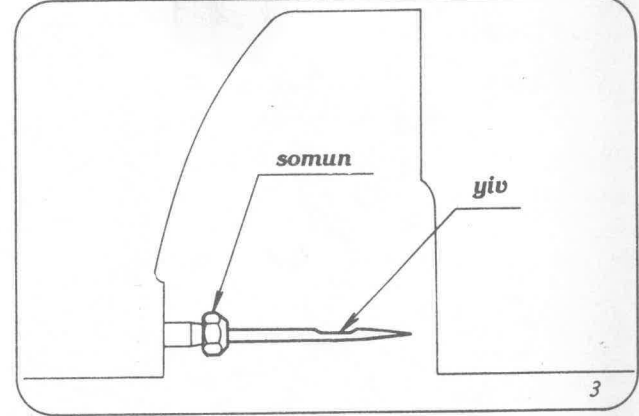
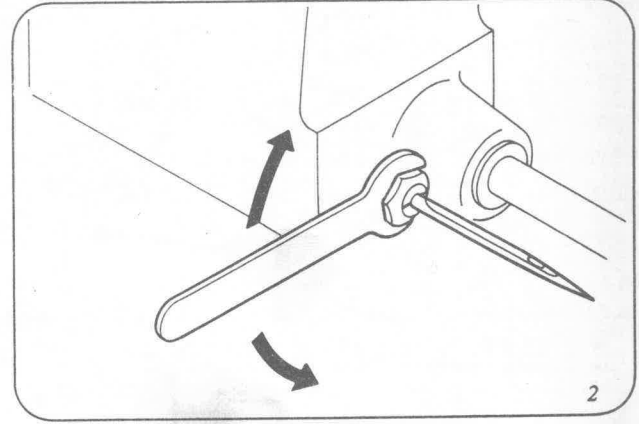
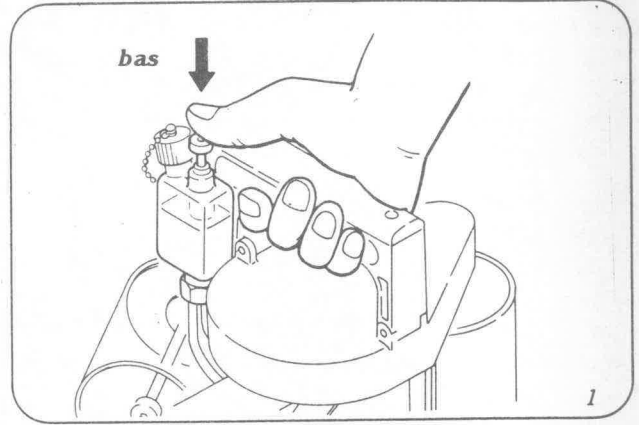
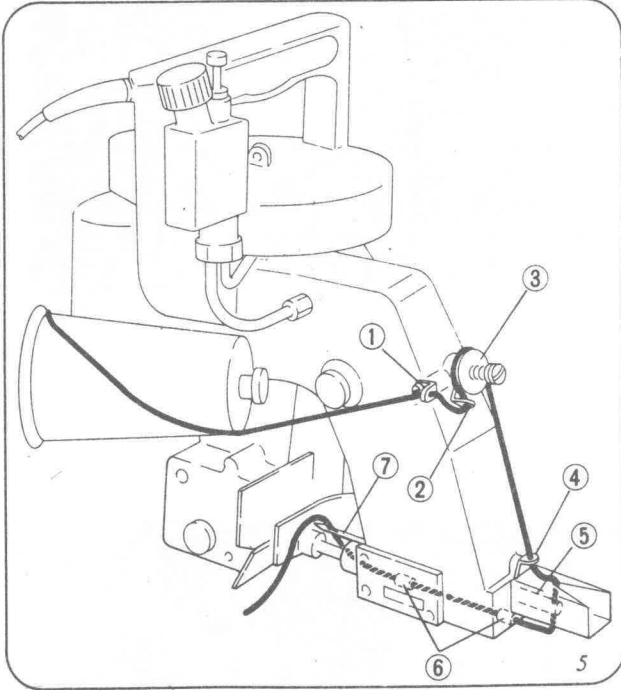

3) ÇALIŞTIRMA

Makinayı çalıştırmadan önce voltajın motora uygun olup olmadığını kontrol ediniz. Makinayı sağ elinizle tutun ve işaret parmağınızı tutma kolunun altındaki düğme üzerine getirin (Şekil 6) Çuvalı sol elinizle tutarak ağzını Besleme Ağızı ile Baskı ayağı arasına itiniz. (Şekil 7)

Çuvalı düz tutarken makinayı çalıştırın. Çuvalı hiçbir zaman öne veya geriye çekmeyiniz. Dikiş bitince 3 cm. uzunluk dikiş bırakınız ve kesme ağızı ile otomatik ipi kesiniz (Şekil 9). Kapalı çuvalı dikmeden önce şayet ilk defa makinayı kullanıyorsanız boş çuval üzerine dikiş yapınız.

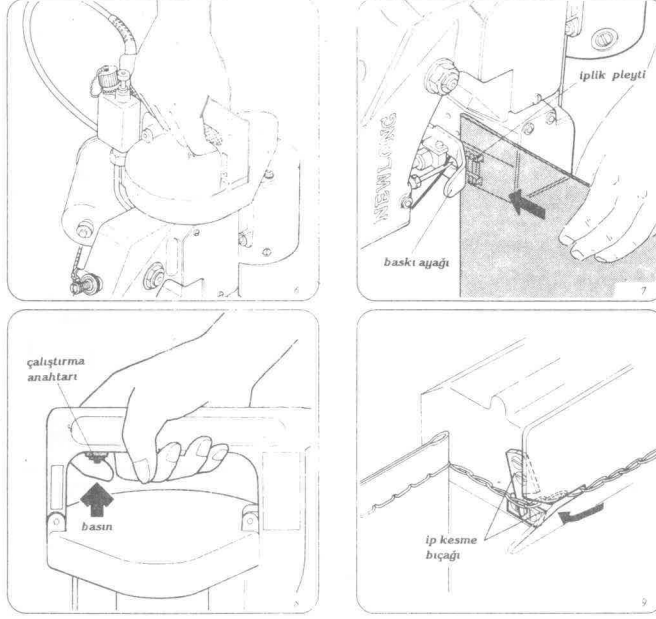

4) AYARLAMA

1. İp Gergisi

İp gerginliği İp Gergi Civatası ile ayarlanır. Sıkmak için saat istikametinde, gevşetmek için ters istikamete çeviriniz. (Şekil 6).

2. Luper ve İğnenin Durumu (Şekil 10)

Luper iğnenin dışbükey yüzünü 0.1 mm hassasiyetle yalamalıdır (Şekil 10). Tolerans ayarı Luper Kavraması vidasının gevşetilmesiyle yapılır.

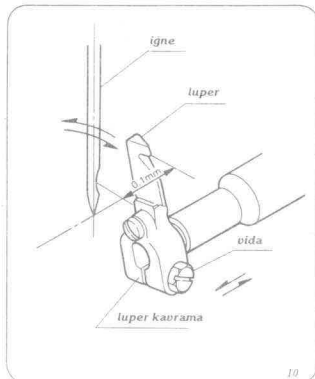

3. Besleme Ağızının Durumu

Besleme Ağızı Şekil 11'deki gibi en yüksek durumda dikiş pleytinin 2.5 mm üstünde olmalıdır. Besleme Ağızının yüksekliği Besleme Ağızı Ayağı Civatasının yüksekliği ile ayarlanır.

4. Baskı Ayağının Baskı Miktarı

Baskı Ayağının baskı miktarını ayarlarken İğne Çubuğunu çıkartın. Baskı Çubuğu Bağlantısının Vidasını gevşetin. Baskı çubuğunu kaldırırsanız baskı artar indirirseniz azalır. Ayardan sonra vidayı sıkılayın.

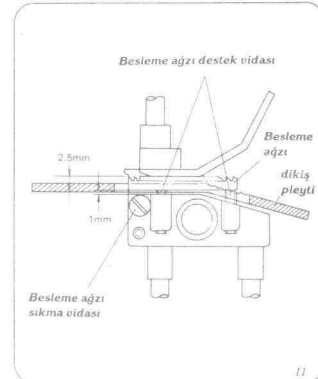

5) PARÇA DEĞİŞTİRME

Mafsal Rodunun değiştirilmesi veya ayarlanması için Şekil 12'ye bakınız. Vidayı çıkartın 1. Rod başını 2. İğne Çubuğu Levyesinde çıkartın 3. Civatayı açtıktan sonra 4. Bağlantı Rodu 4. ile Rod başı 2. arasındaki toleransı ayarlayın. Öyle ki İğne Çubuğu, alt ve üst baskı çubuğu yatakları arasındaki toleransın ortasında hareket etsin (İğne Çubuğu Kutru 37 mm'dir. Eksantrik Kamının 7. Sabitleştirmek için, ana Şaft üzerindeki 8. Vidayı 9. sıkın. (hafifçe değmelidir.) İğnenin durumu (en üst noktadayken iğne ucu ile Dikiş Pleyti arasındaki mesafe 13 mm olmalıdır. (Şekil 12'deki İğne Çubuğu Bağlantı Elemanının 6. Civatasının gevşetilmesiyle).

1. Civata 11/645 40089
2. Rod Başı 6AP058
3. İğne Çubuğu Levyesi 242051 A
4. Somun 1 N 8
5. Bağlantı Rodu Elemanı 242011 A
6. İğne Çubuğu Bağlantı Elemanı 242101A
7. Eksantrik Kamı 242011
8. Ana şaft 241101
9. Civata 11/64540001
10. Ara halkası 241161

Gerektiğinde Luper Hareket Kamını 3 (Şekil 13) 4 aşağıdaki şekilde ayarlayınız.

- a) Civata 2. ve 2'yi Ana Şaft 1 takın.
- b) Birinci Kolu 4. Luper Hareket Kamı 3. ve ikinci kol 5 düz olarak hareket edecek şekilde ayarlayın. Ayardan sonra civatayı 6 sıkın.
- c) Luper Hareket Kamı 3 ile ikinci kol 5 arasındaki tolerans yay 7 ile sağlanır. Civata 9 gevşetin, yay ayağını 8 yay 7 basıncını ayarlamak için çevirin. Ayardan sonra vida 9 sıkın. Yay ayağı 8 sabitleşir.

1. Ana şaft 241101
2. Civata 14/645 28524
3. Luper Hareket Kamı 243012
4. Luper Kavrama Şaft Kolu 243081 (Birinci)
5. Luper Kavrama Şaft Kolu 243071 (İkinci)
6. Luper Kavrama Şaft Kolu Vida 11/64540009
7. Yay 243131
8. Yay Ayağı 243121
9. Yay Ayağı Bloğu Vidası 9/64540035
10. Yay Ayak Bloğu 243122

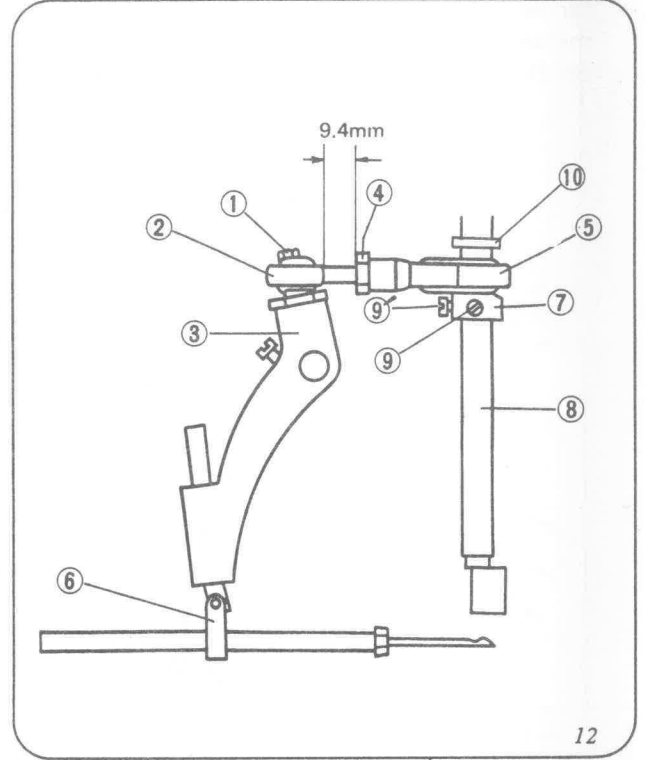

12

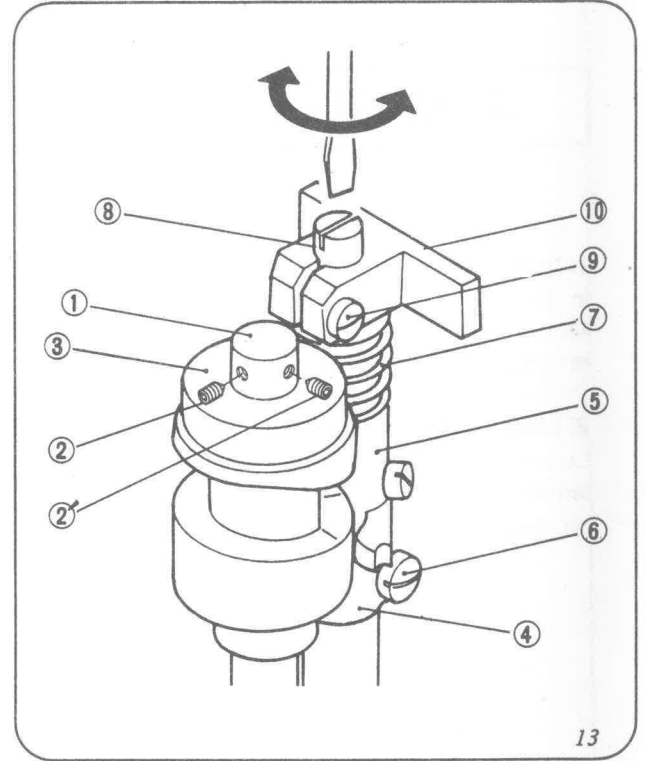

13

6) BAKIM VE YAĞLAMA

Günlük çalışma sonunda makinaryı temizleyiniz. Besleme Ağzının dişleri arasındaki ve Luper ile Dikiş Pleyt üzerindeki tozları, yabancı maddeleri temizleyin. Yağlama için standard makina yağları Shell X - 100, Motor yağı 10W/30, Shell Vitria oil 31 veya muadelleri kullanılabilir.

7) YAĞDANLIK

1. Çalıştırma

Yağdanlık bir pompa ve reserveden oluşur. Reserve 45 cc yağ alır.

Çalıştırmak için :

1. Önce reserve kapağını yarım döndürün.
2. Düğmeyi en alt pozisyonuna kadar itin (12 mm)
3. Bıraktığınız düğme yerine gelecektir.
4. Reserve kapağını yağ kaçırmaması için sıkınız.

2. Bakım

1. Yağ koyarken toz ve yabancı madde içine girmesine mani olun.
2. Yağ verme her seferinde 0.08 cc dir.
3. Reserve polietilendir. Benzin gibi malzeme ile temizlemeyin.

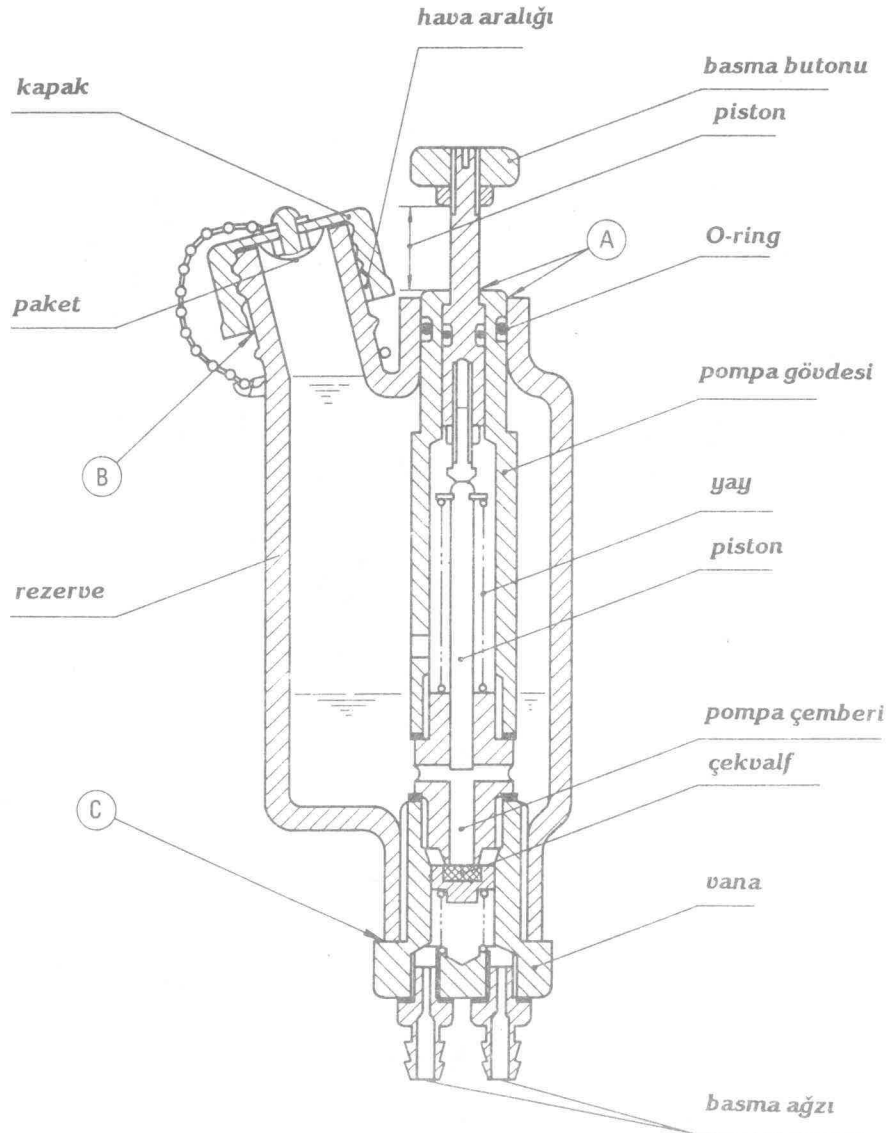

(1) THREAD TENSION AND COVER PARTS
İP GERGİ ve GÖVDE PARÇALARI

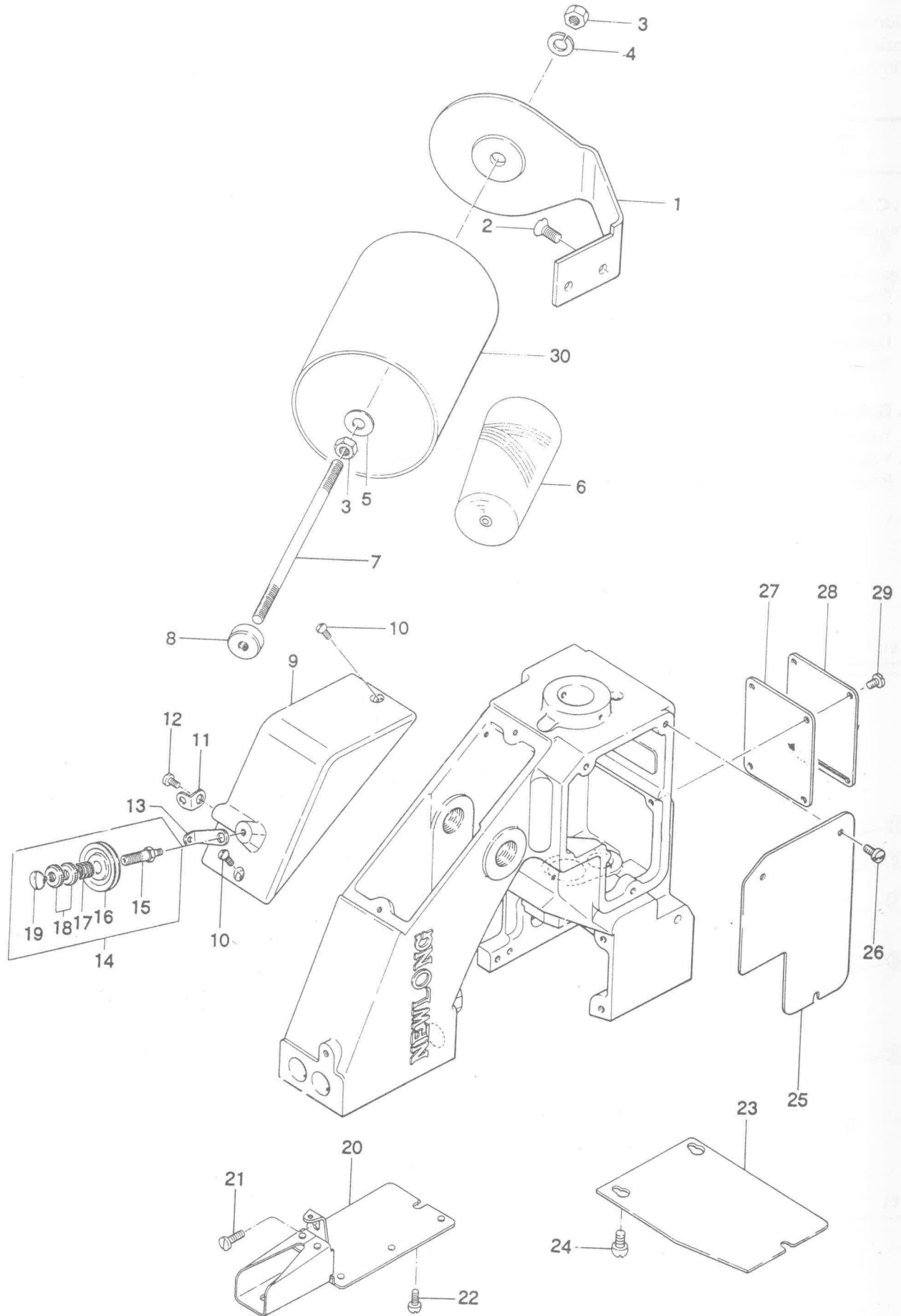

(1) THREAD TENSION AND COVER PARTS

İP GERGİ ve GÖVDE PARÇALARI

Ref No.	Parça No. Part No.	Tanıtım / Description	Adet Q'ty	Açıklama Remarks
1	245042	İplik Standı	1	
2	15/64S28028	Vida 245042 için	2	
3	1N6	Somun	2	
4	3W6	Pul	1	
5	2W6	Pul	1	
6	K01001	İplik	1	
7	245052	İplik Tutma Mili	1	
8	245201	İplik Tutma Somunu	1	
9	245013	Üst Kapak	1	
10	9/64S40043	Civata 245013 için	2	
11	245261	İp Yönlendirici	1	
12	11/64S40005	Vida 245261 için	1	
13	245071	İp Germe Yönlendiricisi	1	
14	245081A	İp Germe	1	(15 - 19)
15	245081	Gergi Direği	1	
16	065261	Gergi Diski	2	
17	245101	Gergi Yayı	1	
18	245091	Gergi Somunu	2	
19	9/64S40011	Vida 245081A için	1	
20	245033	İğne Mili Klavuzu	1	
21	11/64S40005	Vida 245033 için	1	
22	9/64S40065	Vida 245033 için	2	
23	245222	Luper Kapağı	1	
24	9/64S40065	Vida 245222 için	3	
25	245022	Yan Kapak	1	
26	9/64S40005	Vida 245022 için	3	
27	245481	Conta	1	
28	245302	İç Kapak	1	
29	9/64S40005	Vida 245302 için	4	
30	245181	İplik Korumucusu	(1)	Özel Sipariş

(2) BUSHINGS, OILINGS AND HANDLE PARTS
 YAĞLAMA, BURÇLARI ve KULP PARÇALARI

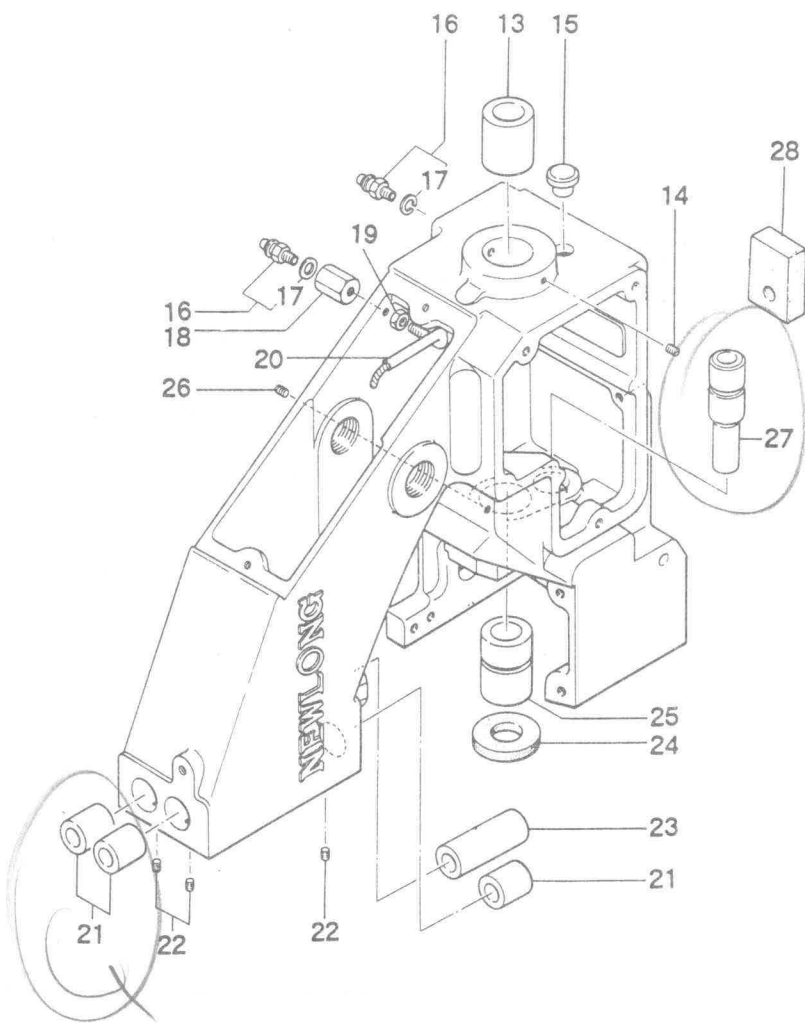
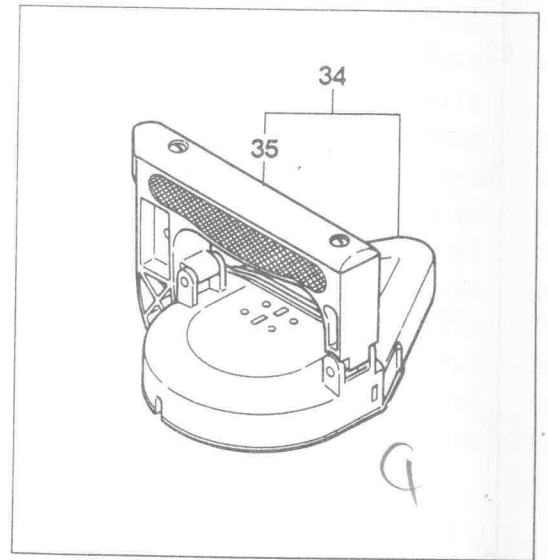
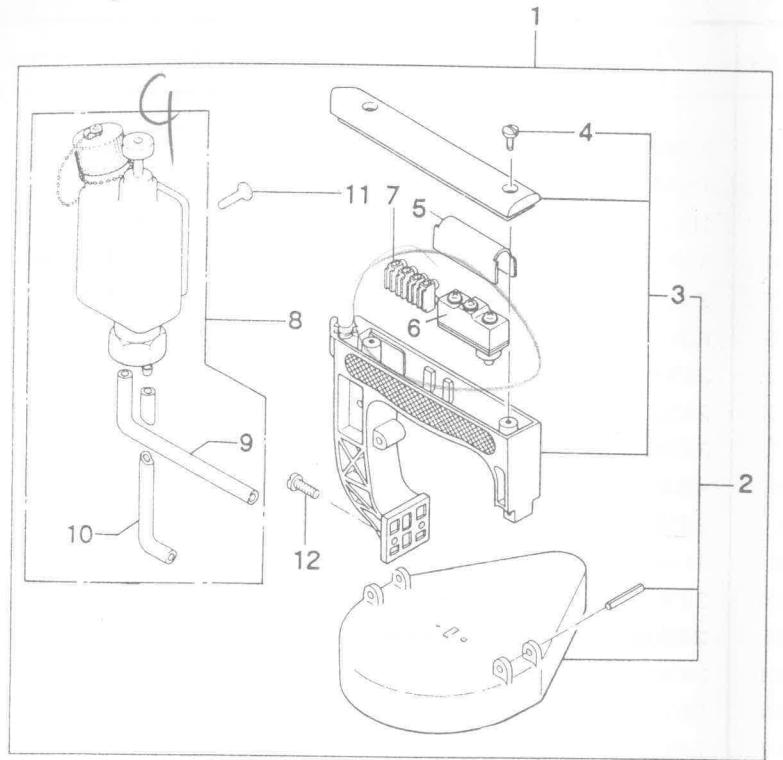
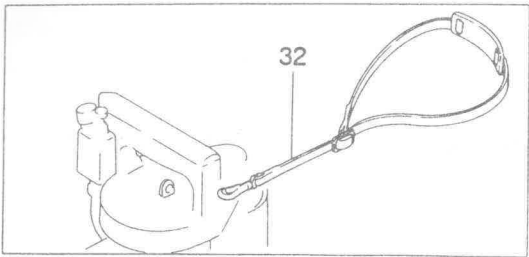
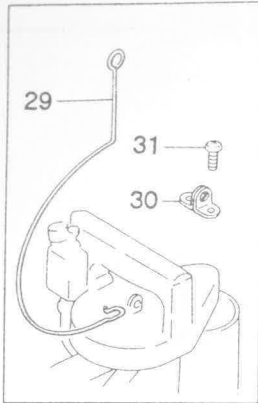
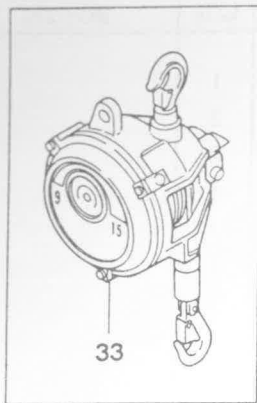

(2) BUSHINGS, OILINGS AND HANDLE PARTS
YAĞLAMA, BURÇLARI ve KULP PARÇALARI

Ref No.	Parça No. Part No.	Tanıtımı / Description		Adet Q'ty	Açıklama Remarks
1	241024AS	Kulp	Handle Assembly	1	(2-11)
2	241024A	Kulp	Handle Assembly	1	(3,4)
3	241024	Kulp	Handle	1	(4)
4	9/64S40011	Vida 241024A için	Screw, for 241024A	2	
5	245132	Şalter Kapağı	Micro Switch Cover	1	
6	C02001	Şalter Z-15GK655-B	Micro Switch (Z-15GK655-B)	1	
7	C02006	Şalter X-10GD-B	Micro Switch (X-10GD-B)	1	DC motor için
	C05008	Terminal ML-SK-1-4P	Flexible Terminal Block (ML-SK-1,4P)	1	
8	D03003	Yağlama Pompası	Oiler	1	(9,10)
9	8FU2-6x90F	Yağ Borusu	Oil Tube, with oil felt	1	
10	8FU2-6x60F	Yağ Borusu	Oil Tube, with oil felt	1	
11	6S5x15	Vida D03003 için	Screw, for D03003	1	
12	15/64S28021	Vida 241024A için	Screw, for 241024A	2	
13	241122	Arka Ana Şaft Burç	Main Shaft Bushing, rear	1	
14	9/64S40502	Vida 241122 için	Screw, for 241122	1	
15	065401	Lastik Burcu	Rubber Bushing	1	
16	D07021	Joint BN-5-6	Joint (BN-5-6)	2	(17)
17	E03014	Pul	Washer	2	
18	245471	Joint	Joint	1	
19	1N4	Somun	Nut	1	
20	245461	Yağ Borusu	Oil Pipe	1	
21	242212	Üst İğne Mili Burcu	Bushing for Presser Bar & Needle Bar, upper	3	
22	9/64S40502	Vida 242212	Screw, for 242212	3	
23	242222	Alt, Baskı Burcu	Presser Bar Bushing, lower	1	
24	205131	Yağ Keçesi	Oil Felt	1	
25	241111	Arka, Ana Şaft Burcu	Main Shaft Bushing, rear	1	
26	9/64S40502	Vida 241111 için	Screw, for 241111	1	
27	243021	Luper Şaft Burcu	Looper Rocker Shaft Bushing	1	
28	245162	Yağ Keçesi	Oil Felt	1	
29	245271	Askı	Hanger	(1)	
30	241151	Çengel	Hook	(1)	Özel Sipariş
31	1/8S40006	Vida 241151 için	Screw,for 241151	(2)	
32	245171	Kemer	Shoulder Belt	(1)	
33	EKT-2.5	Askı	Spring Balancer	(1)	
34	241024BS	Kulp	Handle Assembly (Safety type with pulley cover)	(1)	(2-11)
35	241024B	Kulp	Handle Assembly (Safety type with pulley cover)	(1)	(3,4)

(3) NEEDLE BAR, PRESSER BAR AND DRIVING PARTS
İĞNE MİLİ, BASKI MİLİ, ve HAREKET PARÇALARI

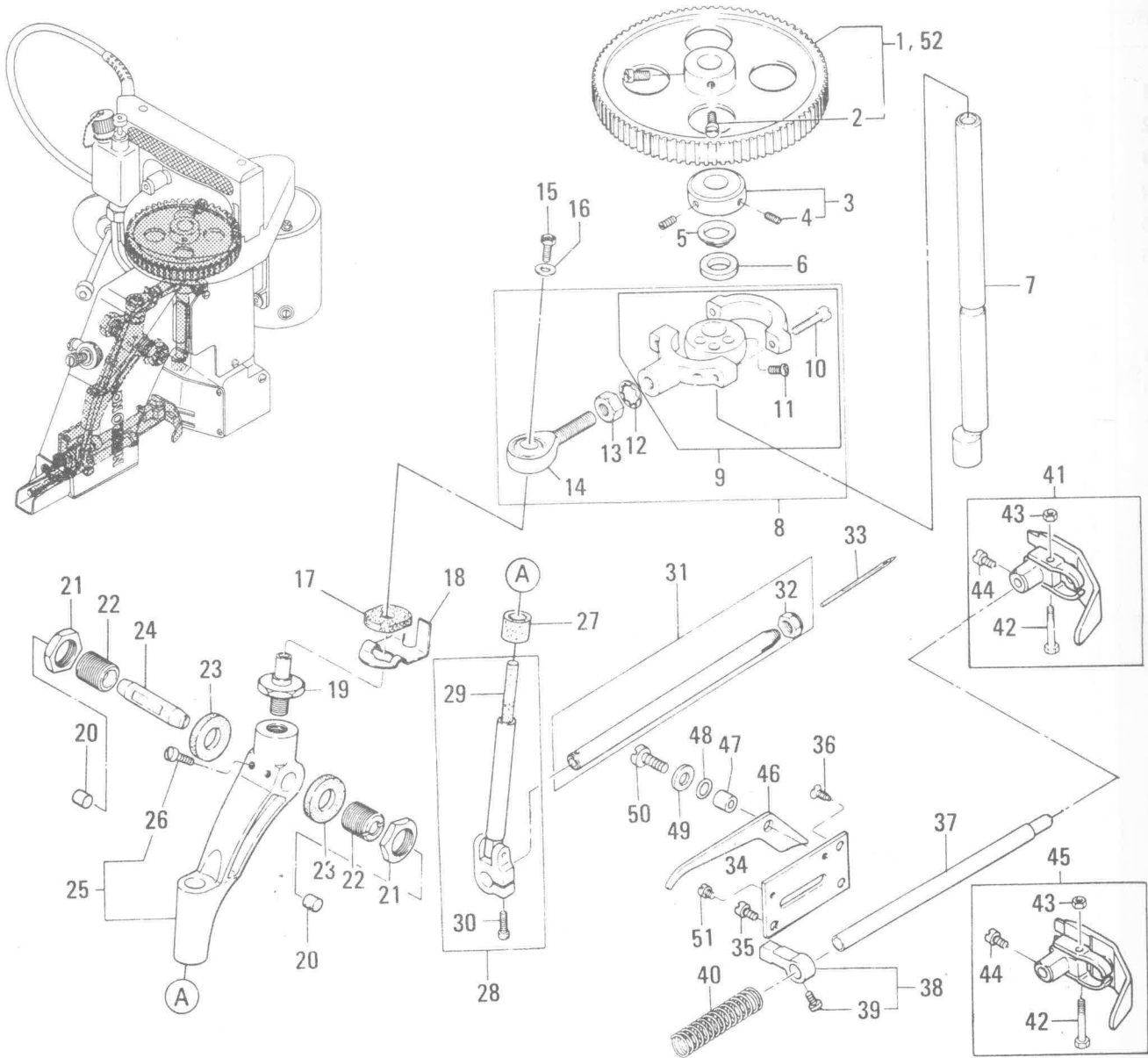

Ref No.	Parça No. Part No.	Tanıtımı / Description		Adet Q'ty	Açıklama Remarks
1	241092	Kasnak	Synchro Pulley	1	(2)
2	3/16S28001	Vida 241092 için	Screw, for 241092	2	
3	241131	Tesbit Bileziği	Retaining Collar	1	(4)
4	11/64S40502	Vida 241131 için	Screw, for 241131	2	
5	241161	Burç	Spacer	1	
6	205131	Yağ Keçesi	Oil Felt	1	
7	241101	Ana Mil	Main Shaft	1	
8	242011A	Rod Başı	Connecting Rod Assembly	1	(9-14)
9	242011	Rod	Connecting Rod Sub - Assembly	1	(10,11)
10	3/16S28029	Vida	Screw, for connecting rod cap	2	
11	11/64S40001	Vida	Screw, for eccentric cam	2	
12	1N8	Somun 242011A için	Nut, for 242011A	1	

(3) NEEDLE BAR, PRESSER BAR AND DRIVING PARTS
İĞNE MİLİ, BASKI MİLİ, ve HAREKET PARÇALARI

Ref No.	Parça No. Part No.	Tanıtım / Description	Adet Q'ty	Açıklama Remarks
13	5W8	Pul 242011A için	1	
14	6A04001	Rod Başı (POS-8)	1	
15	11/64S40089	Vida 242031 için	1	
16	11/64W15103	Pul 242031 için	1	
17	245211	Yağ Keçesi	1	
18	242041	Yay	1	
19	242031	Rod Başı	1	
20	245491	Şapka	2	
21	5/8N18101	Somun 242081 için	2	
22	242081	Ayar Mili	2	
23	245231	Yağ Keçesi	2	
24	242071	İğne Mili Levyesi Sağlama	1	
25	242051A	İğne Mili Levyesi	1	(26)
26	11/64S40004	Vida 242051A için	2	
27	245371	Yağ Keçesi	1	
28	242101A	İğne Mili Bağlantısı	1	(29,30)
29	205171	Yağ Keçesi	1	
30	11/64S40003	Vida 242101A için	1	
31	242121A	İğne Mili ve Somunu	1	(32)
32	242131	İğne Somunu	1	
33	B01002	İğne DN x 1 25 No.	1	
34	242171	Baskı Ayağı Kal.Levyesi	1	
35	11/64S40002	Vida 242171 için	1	
36	11/64S40007	Vida 242171 için	2	
37	242201	İğne Mili	1	
38	242181	İğne Mili Bağlantısı	1	(39)
39	11/64S40003	Vida 242181 için	1	
40	242191	Baskı Yayı	1	
41	242231A	Baskı Ayağı	1	(42-44)
42	9/64S40055	Vida	1	
43	9/64N40101	Somun	1	
44	11/64S40005	Vida 242231A için	1	
45	242233A	Baskı Ayağı (Özel)	(1)	(42-44)
46	242161	Baskı Ayağı	(1)	Özel Baskı
47	242271	Bağlantı	(1)	Ayağı için
48	31LP6	"0" Ring	(1)	Kaldırıcı
49	11/64W15101	Pul	(1)	
50	11/64S40009	Vida 242161 için	(1)	
51	9/64S40001	Vida	(1)	
52	241091	Kasnak	(1)	NP - 7 için

(4) LOOPER DRIVING PARTS
LÜPER HAREKET PARÇALARI

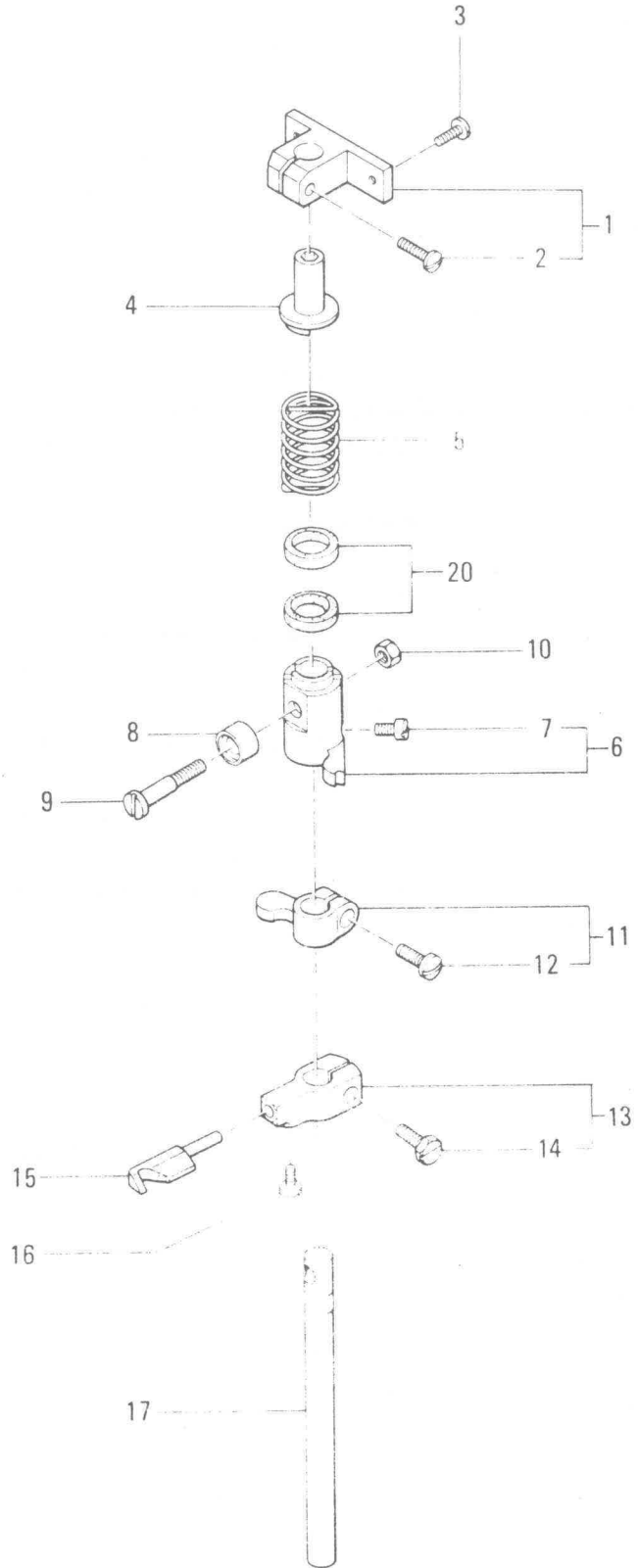
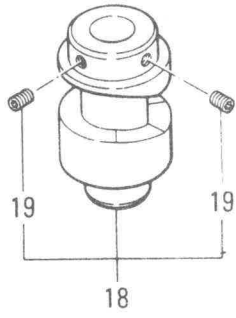
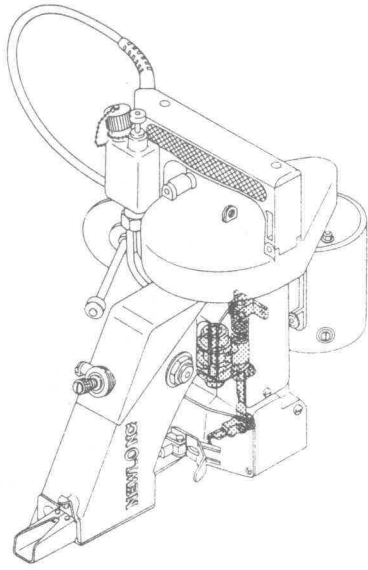

(4) LOOPER DRIVING PARTS
LUPER HAREKET PARÇALARI

Ref No.	Parça No. Part No.	Tanıtımı / Description	Adet Q'ty	Açıklama Remarks
4-1	243111	Yay Destek Bloğu	1	(2)
2	9/64S40035	Vida 243111 için	1	
3	9/64S40005	Vida 243111 için	2	
4	243121	Yay Desteği	1	
5	243131	Yay	1	
6	243071	Luper Kavrama Şaft Kolu (A)	1	(7)
7	11/64S40002	Vida 243071 için	1	
8	243041	Bilezik	1	
9	243061	Bilezik Vidası	1	
10	11/64N40201	Somun 243061 için	1	
11	243081	Luper Kavrama Şaft Kolu (B)	1	(12)
12	11/64S40009	Vida 243081 için	1	
13	243092	Luper Kavramı	1	(14)
14	11/64S40089	Vida 253092 için	1	
15	243102	Luper	1	
16	9/64S40001	Vida 243102 için	1	
17	243032	Luper Kavrama Şaftı	1	
18	243012	Luper Hareket Mili	1	(19)
19	15/64S28524	Vida 243012 için	2	
20	205131	Yağ Keçesi	2	

(5) FEED DRIVING AND THREAD CUTTER PARTS
 BESLEME HAREKETİ ve İP KESİCİ PARÇALARI

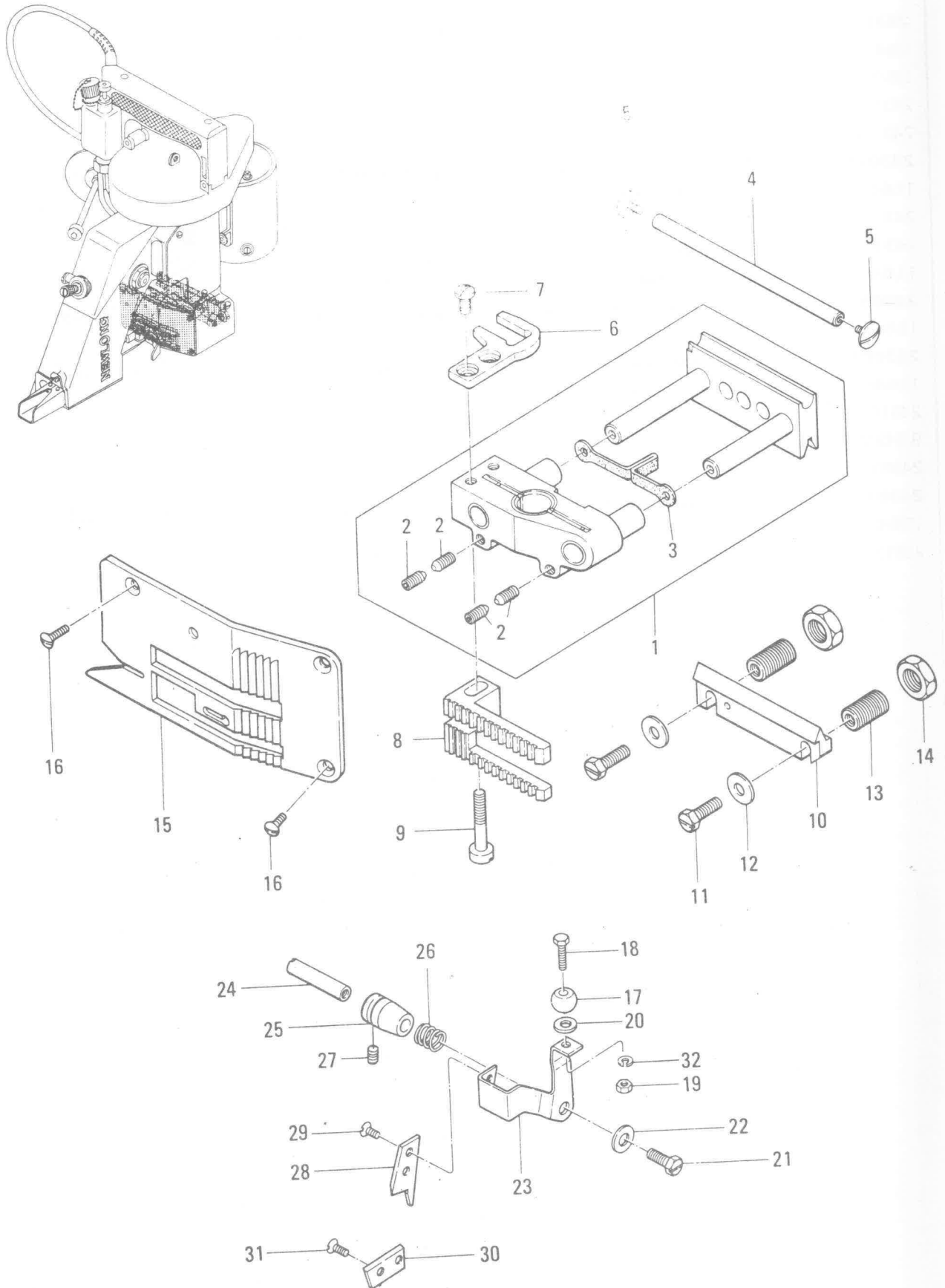

(5) FEED DRIVING AND THREAD CUTTER PARTS
BESLEME HAREKETİ ve İP KESİCİ PARÇALARI

Ref No.	Parça No. Part No.	Tanıtımı / Description		Adet Q'ty	Açıklama Remarks
5-1	244011A	Besleme	Feed Dog Carrier Block Assembly	1	(2,3)
2	1S3/16-32x9	Besleme Destek Civatası	Feed Dog Support Screw (SM3/16x32x9)	4	
3	245391	Yağ Keçesi	Oil Felt	1	
4	244102	Slayt Blok Mili	Slide Block Guide Stud	1	
5	9/64S40011	Vida 244102 için	Screw, for 244102	2	
6	246011	Bıçak Çerçevesi	Knife Bracket Extension	1	
7	3/16S32031	Vida 246011 için	Screw, for 246011	2	
8	244111	Besleme	Feed Dog	1	
9	3/16S32034	Vida 244111 için	Screw, for 244111	1	
10	244081	Slayt Blok Ayarı	Slide Block Adjusting	1	
11	3/16S32025	Kilitleme Somunu 244091 için	Lock Bolt, for 244091	2	
12	11/64W15103	Pul 244091 için	Washer, for 244091	2	
13	244091	Slayt Bloğu Ayar Sağlaması	Stud Slide Block Adjusting Support	2	
14	3/8N24201	Kilitleme Somunu 244091 için	Lock Nut, for 244091	2	
15	244122	Plaka	Throat Plate	1	
16	9/64S40043	Vida 244122 için	Screw, for 244122	3	
17	246081	Bilya	Ball	1	
18	1B3x12	Vida 246021 için	Bolt, for 246081 (M3x0.5x12E)	1	
19	IN3	Somun 246081 için	Nut, for 246081 (M3x0.5)	1	
20	1W3	Pul 246081 için	Washer, for 246081	1	
21	11/64S40049	Vida 246021 için	Screw, for 246021	1	
22	11/64W15103	Pul 246021 için	Washer, for 246021	1	
23	246021	Bıçak Çerçevesi	Knife Bracket	1	
24	246032	Bıçak Pimi	Knife Bracket Pin	1	
25	246042	Vida 246032 için	Bushing, for 246032	1	
26	246051	Bıçak Germe Yay	Knife Tension Spring	1	
27	9/64S40502	Burç 246042 için	Screw, for 246042	1	
28	246061	Hareketli Bıçak	Knife Moving	1	
29	1/8S40003	Vida 246061 için	Screw, for 246061	2	
30	246071	Sabit Bıçak	Knife Stationary	1	
31	1/8S40003	Vida 246071 için	Screw, for 246071	2	
32	3W3	Yay Pulu	Spring Lock Washer (M3)	1	

(6) MOTOR, PARTS (For Totally Enclosed Type Motor)
 MOTOR ve PARÇALARI (Kapalı Motorlar İçin)

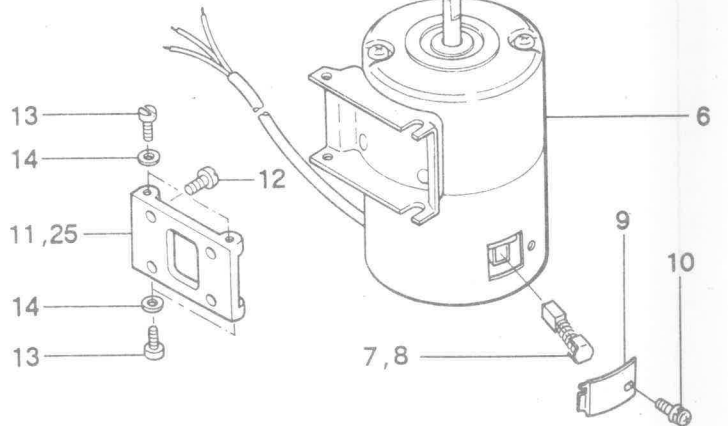
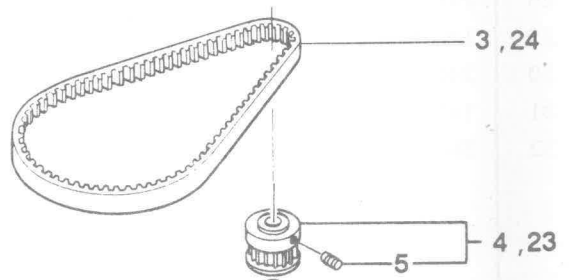
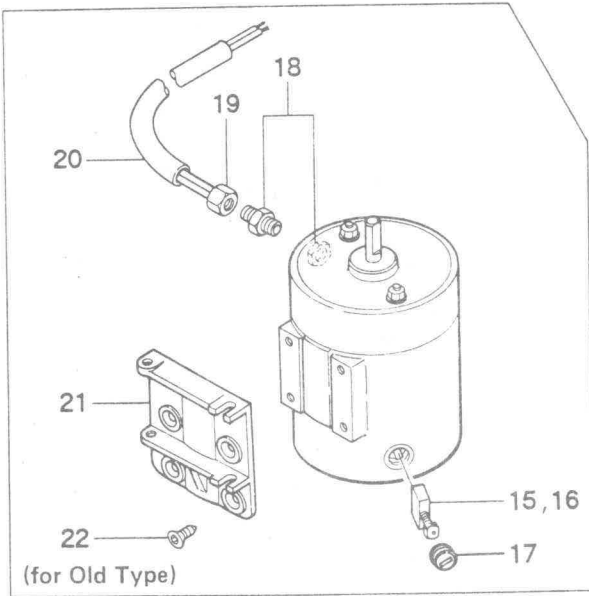
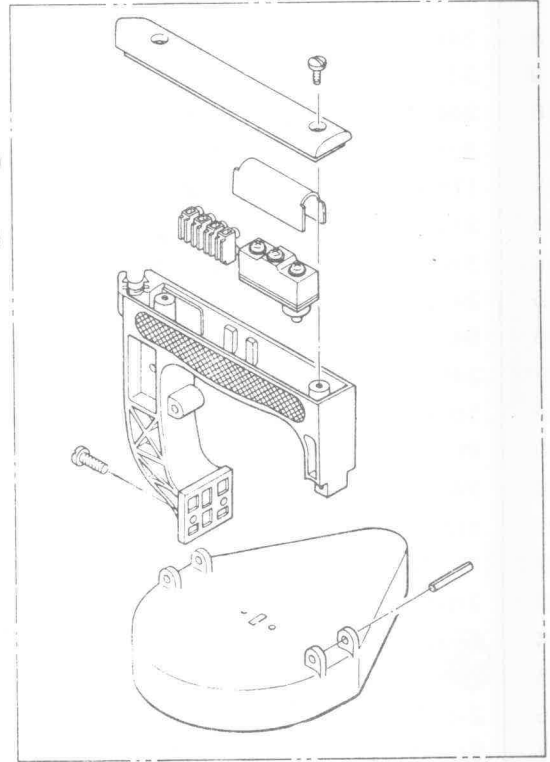
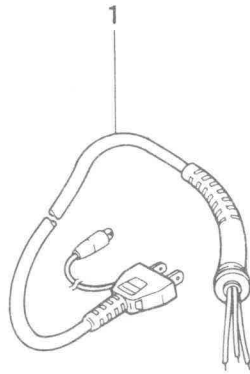
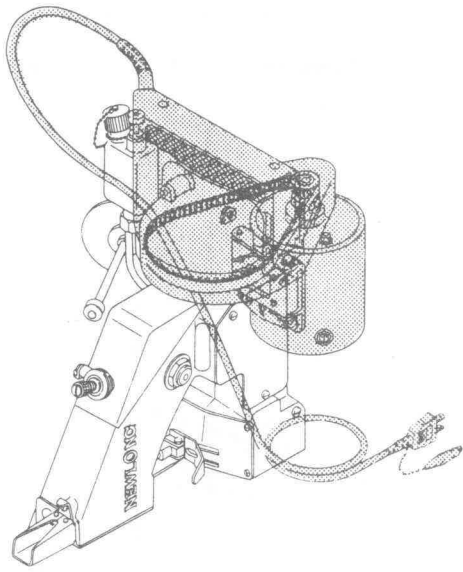

(6) MOTOR, PARTS (For Totally Enclosed Type Motor)

MOTOR ve PARÇALARI (Kapalı Motorlar İçin)

Ref No.	Parça No. Part No.	Tanıtımı / Description		Adet Q'ty	Açıklama Remarks
1	C04001	Kablo Standard	Cabtyer cord, with Plug (Standard Type)	1	
	C04003	Kablo Amerikan Tipi	Cabtyer cord, with Plug (American Type)	1	
	C04004	Kablo İngiliz Tipi	Cabtyer cord, with Plug (British Type)	1	
	C04005	Kablo Alman Tipi	Cabtyer cord, with Plug (German Type)	1	
	C04006	Kablo Fransız Tipi	Cabtyer cord, with Plug (French Type)	1	
	C04007	Kablo Avusturalya Tipi	Cabtyer cord, with Plug (Australian Type)	1	
	C04009	Kablo DC Motor için	Cabtyer cord, with Plug (for DC Motor)	1	
2	211151	Yastık Burç	Rubber Bushing (for C04003-C04007)	1	
3	F01001	Kayış	Timing Belt	1	
4	241083	Motor Kasnağı	Motor Pulley	1	(5)
5	11/64S40504	Vida 241083 için	Screw, for 241083	2	
6	C01010	Universal Motor 110V	Universal Motor (110V)	1	(7,9,10)
	C01011	Universal Motor 220V	Universal Motor (220V)	1	(7,9,10)
	C01012	Universal Motor 240V	Universal Motor (240V)	1	(7,9,10)
	C01013	Universal Motor 24V	Universal Motor (24V)	1	(8-10)
	C01014	Universal Motor 12V	Universal Motor (12V)	1	(8-10)
7	C08004	Kömür AC Motor	Carbon Brush, for AC Motor (size 6x8x15)	2	
8	C07005	Kömür DC Motor	Carbon Brush, for DC Motor (size 6x8x15)	2	
9	C07003	Şapka	Cap	2	
10	4S3x6-W	Vida	Screw (with washer)	2	
11	241073	Motor Şasesi B	Motor Base B	1	
12	15/64S28021	Vida 241073 için	Screw, for 241073	4	
13	11/64S40075	Vida Motor için	Screw, for Motor	4	
14	11/64W10101	Pul Motor için	Washer, for Motor	4	
15	C08001	Kömür AC Motor	Carbon Brush, for AC Motor (size 5x8x14)	(2)	Eski Model
16	C08003	Kömür DC Motor	Carbon Brush, for DC Motor (size 5x8x14)	(2)	
17	C07001	Şapka	Cap	(2)	
18	245321	Bağlantı	Connector B	(1)	
19	245501	Somun	Nut	(1)	
20	245361	kablo Sapı	Cord Cover	(1)	
21	241062	Motor Şasesi A	Motor Base A	(1)	
22	5S10-32x3/8	Vida 241062 için	Screw, for 241062	(4)	
23	241082	Motor Kasnak (Eski Tip)	Motor Pulley (for Old type)	(1)	(5)
24	F01002	Kayış (Eski Tip)	Timing Belt (for Old type)	(1)	NP-7 için
25	241072	Motor Şasesi B	Motor Base B	(1)	

(7) SPECIAL PART FOR NP - 7 H TYPE
NP - 7H ÖZEL PARÇALARI

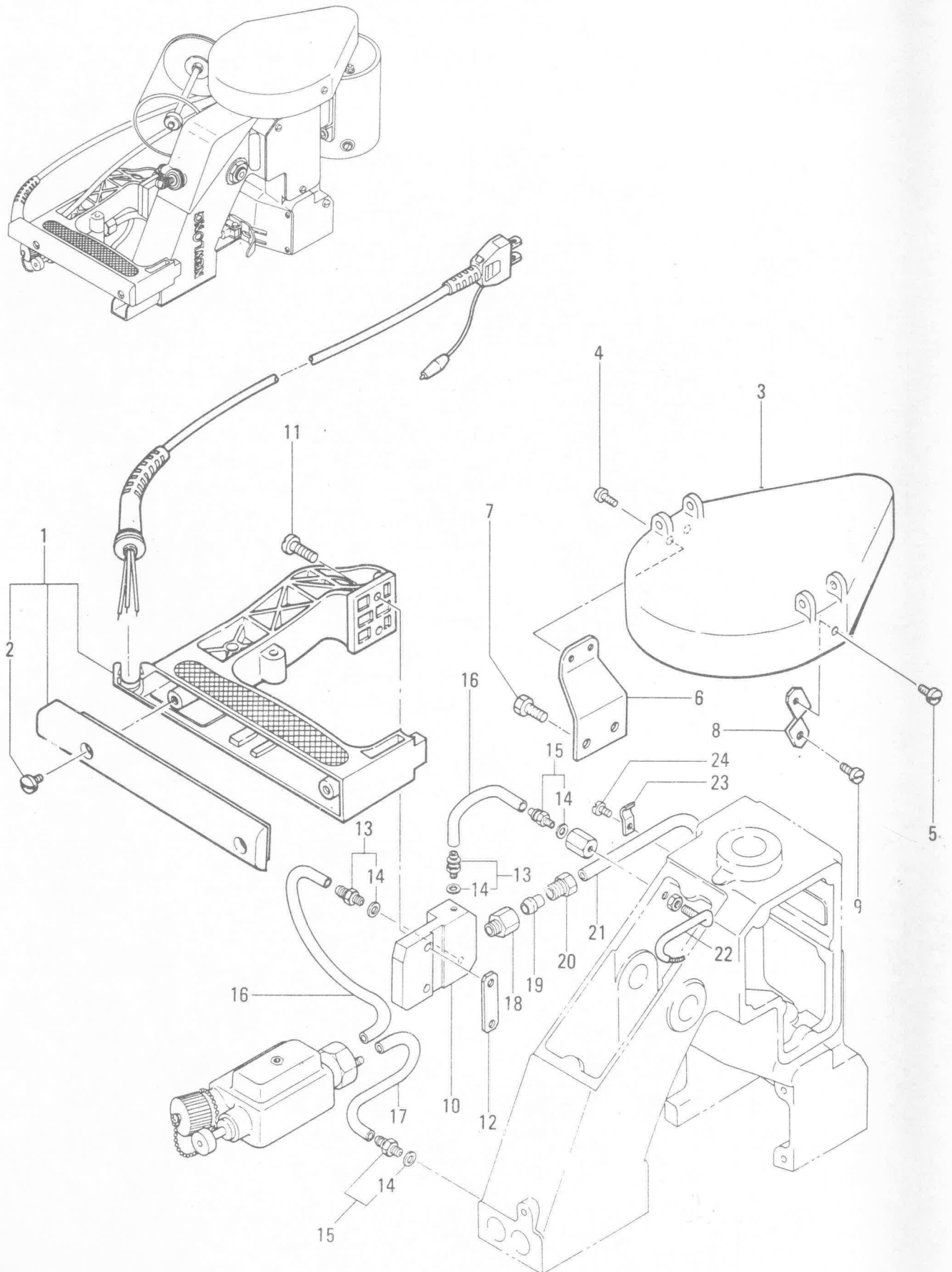

(7) SPECIAL PART FOR NP - 7 H TYPE

NP - 7H ÖZEL PARÇALARI

Ref No.	Parça No. Part No.	Tanıtımı / Description		Adet Q'ty	Açıklama Remarks
7-1	241024	Kol	Handle	1	(2)
2	9/64S40011	Vida	Screw	2	
3	241212	Kasnak Kayışı	Pulley Cover	1	
4	9/64S40004	Vida 241053 için	Screw, for 241053	2	
5	9/64S40052	Vida 241053 için	Screw, for 241053	1	
6	241242	Kasnak Kapağı Kolu A	Pulley Cover Holder A	1	
7	15/64S28004	Vida 241242 için	Screw, for 241242	2	
8	241231	Kasnak	Pulley Cover Holder B	1	
9	9/64S40005	Vida 241231 için	Screw, for 241231	1	
10	241223	Kol Şasesi	Handle Base	1	
11	15/64S28032	Vida 241253 için	Screw, for 241253	2	
12	241253	Kol Şasesi Tutucusu	Handle Base Holder	1	
13	D07021	Bağlantı	Joint (BN-5-6)	2	(14)
14	E03014	Pul	Washer	4	
15	D07021	Bağlantı	Joint (BN-5-6)	2	(14)
16	8FU2-6x95F	Yağ Borusu	Oil Tube (O6x95 E), with oil felt	2	
17	8FU2-6x70F	Yağ Borusu	Oil Tube (O6x70 E), with oil felt	1	
18	D07022	Bağlantı	Joint	1	
19	D07023	Bağlantı	Compression Sleeve	1	
20	D07024	Burç	Compression Bushing	1	
21	8FN2-4x135F	Yağ Borusu	Oil Tube (O4x135 E), with oil wick	1	
22	245462	Yağ Borusu	Oil Pipe	1	
23	D07009	Klepe	Tube Clip (PC-4-1)	1	
24	9/64S40005	Vida D07009 için	Screw, for D07009	1	

(8) CREPE TAPE BINDING AND CUTTER PARTS (Special Order Parts)
 KREP BAND ATAÇMANI ve KESİCİSİ PARÇALARI (Özel Sipariş)

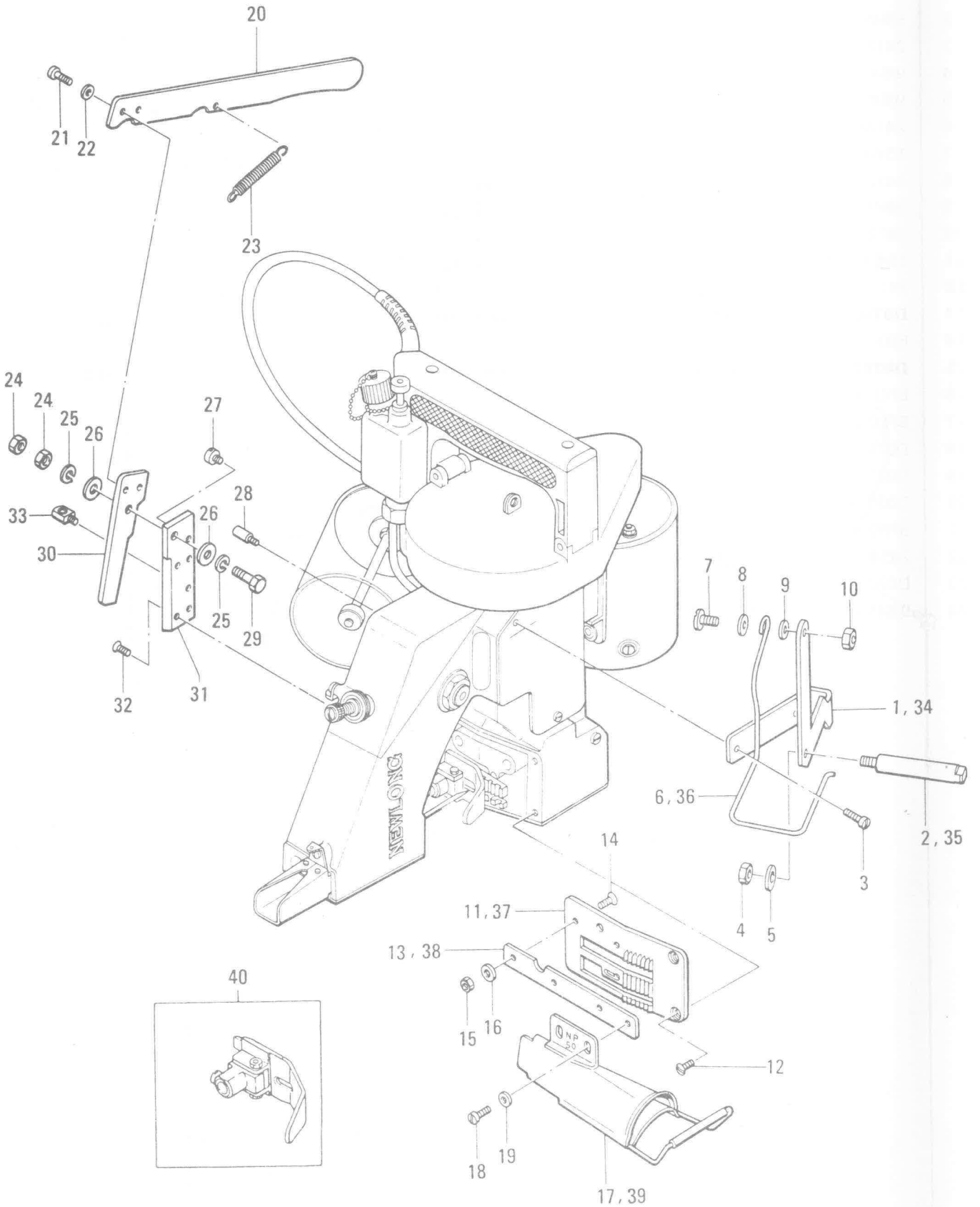

(8) CREPE TAPE BINDING AND CUTTER PARTS (Special Order Parts)

KREP BAND ATAÇMANI ve KESİCİSİ PARÇALARI (Özel Sipariş)

Ref No.	Parça No. Part No.	Tanıtımı / Description		Adet Q'ty	Açıklama Remarks
8-1	247071	Krep Band Çerçevesi	Crepe Tape Bracket	1	
2	247091	Krep Band Askı Sağlaması	Crepe Tape Hanger Stud	1	
3	9/74S40035	Vida 247071 için	Screw, for 247071	2	
4	1 N6	Somun 247091 için	Nut, for 247091	1	
5	2W6	Pul 247091 için	Washer, for 247091 (M6)	1	
6	247081	Krep Band Desteği	Crepe Tape Supporter	1	
7	11/64S40015	Vida 247071 için	Screw, for 247071	1	
8	1/4W03205	Pul 247071 için	Spring Washer, for 247071	1	
9	1/4W15105	Pul 247071 için	Washer, for 247071	1	
10	11/64N40203	Somun 247071 için	Nut, for 247071	1	
11	244132	Plaka	Throat Plate	1	
12	9/64S40043	Vida 244132 için	Screw, for 244132	3	
13	247051	Krep Band Tutma Plakası	Holder, for crepe tape binder	1	
14	9/64S40043	Vida 247051 için	Screw, for 247051	2	
15	9/64N40101	Somun 247051 için	Nut, for 247051	2	
16	2W4	Pul 247051 için	Washer, for 247051 (M4)	2	
17	247061	Krep Band Ataçmanı	Crepe Tape binder	1	
18	9/64S40054	Vida 247061 için	Screw, for 247061	2	
19	2W4	Pul 247061 için	Washer, for 247061 (M4)	2	
20	247031	Kesme Kolu	Cutter Lever	1	
21	11/64S40046	Vida 247011 için	Screw, for 247011	2	
22	11/64W10101	Pul 247011 için	Washer, for 247011	2	
23	247041	Vida 247031 için	Screw, for 247031	1	
24	15/64N28206	Somun 247021 için	Nut, for 247021	2	
25	3W6	Yay Kilit Pulu	Spring Lock Washer, for 247021, (M6)	2	
26	2W6	Pul 247021 için	Washer, for 247021, (M6)	2	
27	11/64S40029	Vida 247011 için	Stopper Screw, for 247011	1	
28	3/16S32026	Vida 247031 için	Stopper Screw, for 247031	1	
29	247021	Pim	Hinge Pin	1	
30	247011	Hareketli Bıçak	Knife, Moving	1	
31	247001	Sabit Bıçak	Knife, Stationary	1	
32	1/8S40003	Vida 247001 için	Screw, for 247001	4	
33	183261	Yay Çengeli	Spring Hook	1	
34	247073	Krep Band Tutucusu	Crepe Tape Bracket	(1)	70 mm Krep
35	247092	Krep Band Tutma Bağlantısı	Crepe Tape Hanger Stud	(1)	Bandlar için
36	247082	Krep Band Desteği	Crepe Tape Supporter	(1)	
37	244133	Plaka	Throat Plate	(1)	
38	247052	Tutucu	Holder, for crepe tape binder	(1)	
39	247063	Aparat	Crepe tape Binder	(1)	
40	242261A	Baskı Ayağı	Presser Foot Assembly	(1)	

İNDEKS
NUMERICAL INDEX OF PARTS

PART NO. PARÇA NO.	PAGE SAYFA	PART NO. PARÇA NO.	PAGE SAYFA	PART NO. PARÇA NO.	PAGE SAYFA
065261	11-16	242212	13-21	245271	13-29
065401	13-15	242222	13-23	245302	11-28
183261	25-33	242231A	15-41	245321	21-18
205131	13-24 14-6	242233A	15-45	245361	21-20
	17-20	242261A	25-40	245371	15-27
205171	15-29				
		242271	15-47	245391	19-3
211151	21-2	243012	17-18	245461	13-20
		243021	13-27	245462	23-22
241024	13-3 23-1	243032	17-17	245471	13-18
241024A	13-2	243041	17-8	245481	11-27
241024AS	13-1				
		243061	17-9	245491	15-20
241024B	13-35	243071	17-6	245501	21-19
241024BS	13-34	243081	17-11	246011	19-6
24162	21-21	243092	17-13	246021	19-23
241072	21-25	243102	17-15	246032	19-24
241073	21-11				
		243111	17-1	246042	19-25
241082	21-23	243121	17-4	246051	19-26
241083	21-4	243131	17-5	246061	19-28
241091	15-52	244011A	19-1	246071	19-30
241092	14-1	244081	19-8 19-10	246081	19-17
241101	14-7				
		244091	19-13	247001	25-31
241111	13-25	244102	19-4	247011	25-30
241122	13-13	244111	19-8	247021	25-29
241131	14-3	244122	19-15	247031	25-20
241151	13-30	244132	25-11	247041	25-23
241161	14-5				
		244133	24-37	247051	25-13
241212	23-3	245013	11-9	247052	25-38
241223	23-10	245022	11-25	247061	25-17
241231	23-8	245033	11-20	247063	25-39
241242	23-6	245042	11-1	247071	25-1
241253	23-12				
		245052	11-7	247073	25-34
242011	14-9	245071	11-13	247081	25-6
242011A	14-8	245081A	11-14	247082	25-36
242031	15-19	245081	11-15 11-30	247091	25-2
242041	15-18	245091	11-18	247092	25-35
242051A	15-25				
		245101	11-17		
242071	15-24	245132	13-5		
24081	15-22	245162	13-28		
242101A	15-28	245171	13-32		
24121A	15-31	245181	11-30		
24231	15-32				
		245201	11-8		
24161	15-46	245211	15-17		
242171	15-34	245222	11-23		
242181	15-40	245231	15-23		
242191	15-40	245261	11-11		
242201	15-37				

İNDEKS
NUMERICAL INDEX OF PARTS

PART NO. PARÇA NO.	PAGE SAYFA	PART NO. PARÇA NO.	PAGE SAYFA	PART NO. PARÇA NO.	PAGE SAYFA
OTHER ITEMS DİĞERLERİ		SCREW VİDALAR		15/64S28524	17-19
6A04001	15-14	1/8S40003	19-29 19-31	1B3x12	19-18
B01002	15-33		25-32	1S3/16-32x9	19-2
C01010	21-6	1/8S40006	13-31	4S3x6-W	21-10
		3/16S28001	14-2	5S10-32x3/8	21-22
C01011	21-6			6S5x15	13-11
C01012	21-6	3/16S28029	14-10		
C01013	21-6	3/16S32025	19-11		
C01014	21-6	3/16S32026	25-28		
C02001	13-6	3/16S32031	19-7		
		3/16S32034	19-9		
C02006	13-6			NUT SOMUNLAR	
C04001	21-1	9/64S40001	15-51 17-16	1N3	19-19
C04003	21-1	9/64S40004	23-4	1N4	13-19
C04004	21-1	9/64S40005	11-26 11-29	1N6	11-3 25-4
C04005	21-1		17-3 23-9		
			23-24	1N8	14-12
C04006	21-1	9/64S40011	11-19 13-4	3/8N24201	19-14
C04007	21-1		19-5 23-2	5/8N18101	15-21
C04009	21-1	9/64S40035	17-2 25-3	9/64N40101	15-43 25-15
C05008	13-7			11/64N40201	17-10
C05001	21-17	9/64S40043	11-10 19-16		
			25-12 25-14	11/64N40203	25-10
C07003	21-9	9/64S40052	23-5	15/64N28206	25-24
C08001	21-15	9/64S40054	25-18		
C08003	21-16	9/64S40055	15-42		
C08004	21-7	9/64S40065	11-22 11-24		
C08005	21-8				
		9/64S40502	13-14 13-22		
D03003	13-3		13-26 19-27	WASHER PULLAR	
D07009	23-23	11/64S40001	14-11	1W3	19-20
D7021	13-16	11/64S40002	15-35 17-7	2W4	25-16 25-19
	23-13 23-15	11/64S40003	15-30 15-39	2W6	11-5 25-5
D07022	23-18	11/64S40004	15-26		25-26
D07023	23-19			3W3	19-32
		11/64S40005	11-12 11-21	3W6	11-4 25-25
D07024	23-20		15-44	5W8	15-13
F01001	21-3	11/64S40007	15-36	1/4W03205	25-8
F01002	21-24	11/64S40009	15-50 17-12		
K01001	11-6	11/64S40015	25-7		
8FNx135F	23-21	11/64S40029	25-27	1/4W15105	25-9
				11/64W10101	21-14 25-22
8FU2-6x60F	13-10	11/64S40046	25-21	11/64W15101	15-49
8FU2-6x70F	23-17	11/64S40049	19-21	11/64W15103	15-16 19-12
8FU2-6x90F	13-9	11/64S40075	21-13		19-22
8FU2-6x65F	23-16	11/64S40089	15-15 17-14	E03014	13-17 23-14
EKT-2.5	13-33	11/64S40502	14-4		
31LP6	15-48	11/64S40504	21-5		
		15/64S28004	23-7		
		15/64S28021	13-12 21-12		
		15/64S28028	11-2		
		15/64S28032	23-11		

NP-7A

SCREW, NUT & WASHER
VİDA SOMUN & PULLAR

1/1 ÖLÇÜ
FULL SIZE



9/64S40502 11/64S40502 11/64S40504 15/64S28524 1/8S40006 9/64S40001 9/64S40004 9/64S40052 9/64S40054



9/64S40011 9/64S40065 9/64S40005 9/64S40035 11/64S40029 11/64S40001 11/64S40002 11/64S40009 11/64S40006

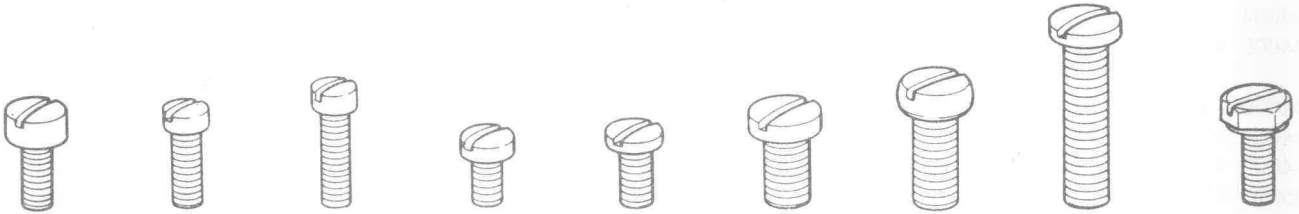

11/64S40046 11/64S40003 11/64S40004 11/64S40005 3/16S32031 15/64S28004 15/64S28021 15/64S28032 11/64S40084

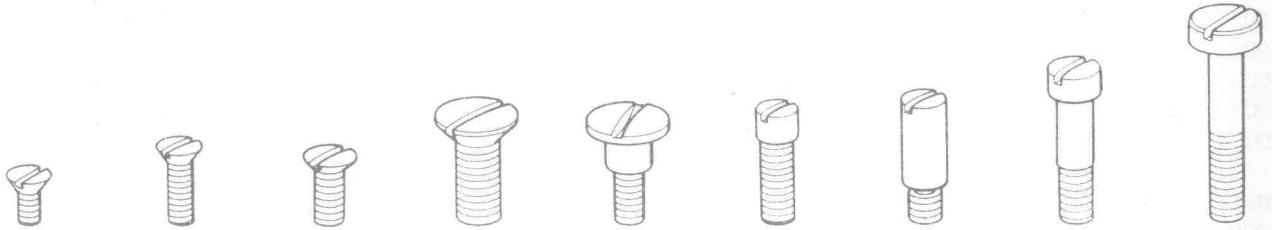

1/8S40003 9/64S40043 11/64S40007 15/64S28028 11/64S40015 3/16S28001 3/16S32026 3/16S28029 3/16S32034

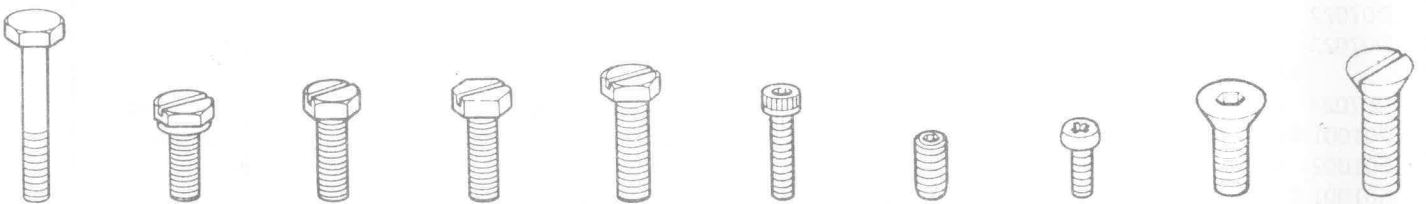

9/64S40055 11/64S40049 11/64S40075 11/64S40089 3/16S32025 **4B3x12** 1S3/16-32x9 4S3x6-W FC103238 6S5x15

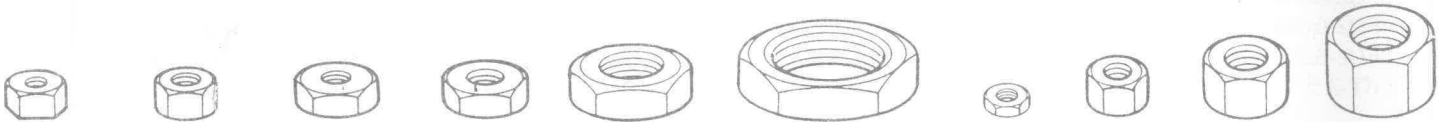

9/64N40101 11/64N40201 11/64N40203 15/64N28206 3/8N24201 5/8N18101 1N3 1N4 1N6 1N8



11/64N40102



11/64W10101 11/64W15103 1/4W03205 1/4W15105 1W3 2W4 2W6 3W3 3W6 5W8 E03014

本社

東京都台東区東上野6-4-14
〒110-0015

TEL 03-3843-7311(代)
FAX 03-3843-9998

海外事業部
東京都台東区東上野6-4-14
〒110-0015

TEL 03-3843-0269
FAX 03-3843-0260

営業所

小樽・小樽市銭函2-17-2
〒047-0261
仙台・仙台市若林区遠見塚3-14-10
〒984-0823
東京・東京都足立区大谷田4-3-17
〒120-0001
鹿島・茨城県神栖市知手6117-1
〒314-0115
千葉・千葉市中央区末広5-12-2
〒260-0843
横浜・横浜市鶴見区元宮1-17-3
〒230-0004
静岡・静岡市清水区袖師町503
〒424-0037

TEL 0134-62-2691(代)
FAX 0134-62-2682
TEL 022-286-5189
FAX 022-286-8230
TEL 03-3629-2691(代)
FAX 03-3629-2695
TEL 0299-96-4612
FAX 0299-96-7359
TEL 043-263-1542
FAX 043-266-6546
TEL 045-584-2691(代)
FAX 045-584-9450
TEL 0543-64-2691(代)
FAX 0543-65-2533

名古屋・名古屋市中川区百船町13-5
〒454-0801
富山・富山市下富居1-1-36
〒930-0814
大阪・大阪市福島区大開2-1-8
〒553-0007
岡山・岡山市中区海吉1844-5
〒703-8261
坂出・坂出市江尻町1460-4
〒762-0011
広島・広島市中区舟入町7-28
〒730-0841
福岡・福岡県粕屋郡新宮町下府2-10-46
〒811-0112

TEL 052-351-2691(代)
FAX 052-363-3691
TEL 076-441-2690
FAX 076-431-3691
TEL 06-6462-4351(代)
FAX 06-6465-5926
TEL 086-277-6527
FAX 086-277-6528
TEL 0877-46-3659(代)
FAX 0877-46-3662
TEL 082-293-2691(代)
FAX 082-295-6516
TEL 092-962-4006(代)
FAX 092-963-0249

出張所

旭川・旭川市永山5条4丁目
〒079-8415
青森・青森市富田4-28-1
〒038-0004
新潟・新潟市東区桃山町1-109-5
〒950-0051
郡山・郡山市安積町荒井大池2番地
〒963-0111
栃木・栃木市川原田町280-3
〒328-0123
群馬・群馬県佐波郡玉村町大字上茂木490-1
〒370-1122

TEL 0166-47-3267
FAX 0166-48-1654
TEL 017-766-2691
FAX 017-766-7082
TEL 025-275-1451
FAX 025-273-8488
TEL 0249-47-7042
FAX 0249-47-7043
TEL 0282-23-3981
FAX 0282-23-3809
TEL 0270-65-0883
FAX 0270-65-0889

長野・長野県東御市滋野乙2508-5
〒389-0512
滋賀・滋賀県栗東市大橋1-10-30
〒520-3046
高砂・高砂市阿弥陀町北池9-2
〒676-0825
小郡・山口市大字江崎3640-1
〒754-0896
鹿児島・鹿児島市小松原1-1-10
〒891-0114

TEL 0268-64-2691
FAX 0268-64-2619
TEL 077-553-2691
FAX 077-553-7846
TEL 0794-47-2570
FAX 0794-47-2807
TEL 0839-89-2691
FAX 0839-89-4999
TEL 099-268-3235
FAX 099-267-6023

NEWLONG MACHINE WORKS, LTD.

HEAD OFFICE

: 4-14, Higashi-ueno 6-chome, Taito-ku, Tokyo 110-0015, Japan
TEL : (81)3-3843-0269 FAX : (81)3-3843-0260
E-mail : bagging@newlong.com (Plant & Business Development)
TEL : (81)3-3843-6548 FAX : (81)3-3843-0260
E-mail : sewing@newlong.com (Sewing Machine)
TEL : (81)3-3843-0258 FAX : (81)3-3843-9963
E-mail : bag_making@newlong.com (Bag Making)
TEL : (81)3-3843-0259 FAX : (81)3-3843-9963
E-mail : shipping@newlong.com (Shipping)

NEWLONG PACKAGING MACHINERY (BEIJING) CO., LTD.

: No.31, Yongxing Street Bioengineering & Pharmaceutical Industrial Area Daxing, Beijing 102600, P. R. China
TEL : (86) 10-6127-1688
FAX : (86) 10-6127-2475

NEWLONG PACKAGING MACHINERY (BEIJING) CO., LTD.(SHANGHAI BRANCH)

: #2002, 20F Tower D80, Caobao Road, Xuhui District,, Shanghai 200235, P. R. China
TEL : 86(21)-6432-6491(直通) 6432-5955-6(共用)
FAX : 86(21)-6432-6493(直通) 6432-5512(共用)

NEWLONG TAIWAN MACHINE CO. LTD.

: No.12, Lane 175, Jhongsing N.st., Sanchong City, Taipei Hsien, 24158, Taiwan
TEL:886(2)-2278-2297 FAX:886(2)-8512-2672
E-mail : newlong@ms43.hinet.net

NEWLONG SINGAPORE PTE. LTD.

: 68, Kian Teck Road, Jurong Town, Shingapore-628 795, Singapore
TEL : (65)6261-2126, 6265-0901, FAX : (65)6265-1994
E-mail : newlong@singnet.com.sg

NEWLONG MALAYSIA SDN.BHD.

: 24, Jalan Pju 3/45, Sunway Damansara Technology Park, 47810 Petaling Jaya, Selangor, Malaysia
TEL:60(3)-7805-2988 FAX:60(3)-7804-7099
E-mail : newlong@tm.net.my

NEWLONG MALAYSIA SDN.BHD. (JOHOR BRANCH)

No. 19A, Jalan Molek 2/37 Taman Molek 81100, Johor Bahru, Johor, Malaysia
TEL : 60(7)-356-0254 FAX : 60(7)-356-0257 E-mail : nljb@tm.net.my

PT NEWLONG INDONESIA

: JL. Duren Tiga Selatan VII No.7 Jakarta 12760 Indonesia
TEL : 62(21)-7919-5945, 7919-5946 FAX : 62(21)-7919-5947
E-mail : sales@newlong.co.id

NEWLONG (THAILAND) LTD.

: 1415 Between Soi 63-65, Sukhumvit Road,Prakanong-Nua, Wattana, Bangkok 10110, Thailand
TEL : 66-2891-1171, 66-2714-0600-4 FAX:66-2391-5508
E-mail : tsuji@newlongthai.com(0000@newlongthai.com)

NEWLONG FZE

: P. O. BOX 61282 Jebel Ali, Free Zone, Dubai,U.A.E.
TEL : 971(4)881-7188 FAX : 971(4)881-9882
E-mail : dubai@newlong-fze.com

NEWLONG HOLLAND B.V.

: Capronilaan 10, 1119 NR, Schiphol-Rijk, The Netherlands
TEL : 31(0)20-653-2350 FAX : 31(0)20-653-2416 E-mail : sales@newlong.nl

AMERICAN-NEWLONG, INC.

: 5310 South Harding Street, Indianapolis, IN 46217 U. S. A.
TEL : 1(317)787-9421 FAX : 1(317)786-5225
E-mail : newlong@american-newlong.com

NEWLONG LATIN AMERICA INC.

: 2700 N. W. 112th Avenue Miami, FL 33172, U. S. A.
TEL : 1(305)406-1038, 406-1024 FAX : 1(305)406-1039 E-mail : newlong@mindspring.com

NEWLONG DE MEXICO S. A. DE. C. V.

: Av. 8 de Julio #1510 Colonia Morelos Guadalajara, Jalisco C. P. 44943 Mexico.
TEL : 52(3)344-8086, 8087 FAX : 52(3)344-8084 E-mail : newlong@megared.net.mx

NEWLONG HASEBRAS MAQUINAS INDUSTRIAIS, LTDA.

: Rua. Francisco Tapajos, 409-415 Jardim da Saude, CEP 04153-000 Sao Paulo, Brasil
TEL : 55(11)5073-9744 FAX : 55(11)5073-9084 E-mail : hasegawa@newlongbr.com.br



Gedikli Enka

**Machine Mills Industrial Equipments Spare Parts Trade Group
Head Office;**

Perpa Ticaret Merkezi A Blok K.7-8-9 N.714 34384 Okmeydanı Şişli-İSTANBUL/TÜRKİYE
Tel: 0212 3203664 Fax: 0212 3203692 7/24 Gsm:0532 4370435
s.ayhangedikli@hotmail.com s.ayhangedikli@enkagedikli.com

www.enkagedikli.com: www.nasadegirmen.com www.newlongdikismakinalari.com www.polyestercuvaldikisipi.com

Flour-Feed-Food Industrial Machine Equipments Spare Parts.

NEWLONG MACHINE WORKS, LTD.

14-14MATSUGAYA 1-CHOME, TAITO-KU
TOKYO, JAPAN
TEL:03(3843)6548
FAX:03(3843)6574

No.32

1003-32-1000-NP-7A(BJ)



Newlong Machine Works.,Ltd.Tokyo-Japan

www.newlong.com

YETKİLİ BAYİİ VE SERVİS İS :